

DTR, DTU

Description

Thermometers can be used for temperature measurement in any position. Thermometer head can be placed in environment with temperature range -30 °C to +80 °C. The maximum permissible deviation is ±2,5 % scale range for all versions. Measured temperature must not exceed maximum scale range.

Thermometers are manufactured with various stem lengths as shown in the table. The whole measuring system must be placed in measured environment to ensure accurate measurement. Recommended installation depth P is 100 mm, or the whole length of shorter stems. In some cases, especially at pressure bigger than 0,3 MPa or in liquid environment, stem must be placed in thermometer well. Maximum pressure when well is used is 0,6 MPa. Thermometers with range 0 °C - 350 °C and 0 °C - 450 °C can be used only with thermometer well.

Thermometer consists from plastic head and stem. Stem can be made from stainless steel or non-alloy steel call 11 (length up to 400 mm), or from made of non-alloy steel only (length 630 mm or bigger). Stem from length 630 mm is coated with protective varnish. Scale is protected by glass.



Technical data

Type	Scale division [°C]	Scale range [°C]	Measuring range [°C]	Stem length ... L [mm]						
				ø d = 8 mm (stainless (AKVS))				ø d = 12 mm (steel cl. 11)		
				60	100	160	250	400	630	1000
DTR	1	-30 to 50	-20 to 40 x	x	x	x	x	x	x	x
	1	0 to 120	20 to 100 x	x	x	x	x	x	x	x
	2	0 to 200	20 to 180 x	x	x	x	x	x	x	x
	5	0 to 350	50 to 300	x	x	x	x	x	x	x
	10	0 to 450	50 to 400	x	x	x	x	x	x	x
DTU	1	-30 to 50	-20 to 40	x	x	x	x	x	x	x
	1	0 to 120	20 to 100	x	x	x	x	x	x	x
	2	0 to 200	20 to 180	x	x	x	x	x	x	x
	5	0 to 350	50 to 300	x	x	x	x	x	x	x
	10	0 to 450	50 to 400	x	x	x	x	x	x	x

Ordering

Thermometer type, quantity, scale range, stem length, stem material must be specified in order. Accessory design (thermometer well, adjustable socket) must be also specified if required.

Technical drawings

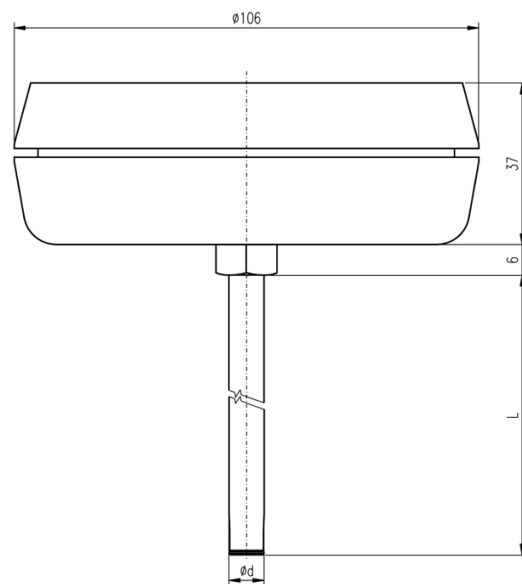
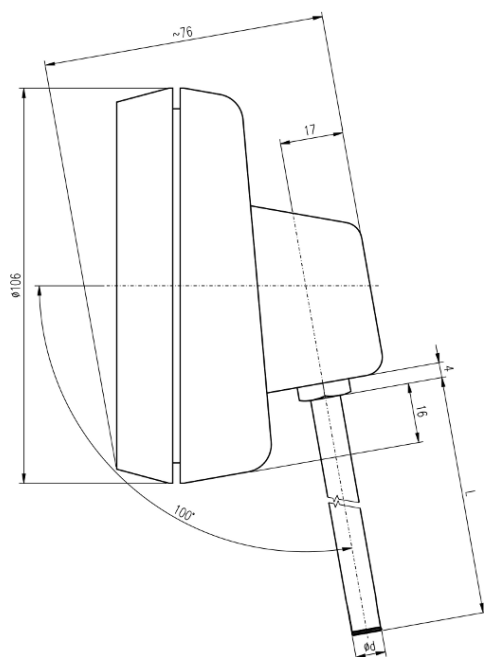

Contacts

APATOR METRA s. r. o.

Havlíčková 919/24
787 01 Šumperk
Czech Republic

Tel.: +420 583 718 261
Fax.: +420 583 718 150
E-mail: prodej@metra-su.cz
WWW: www.metra-su.cz

Your distributor:

The manufacturer reserves the right to change design, technical specifications and accessories without prior notice.