

new



Elf 2

Compact heat and cooling meter -
- the latest generation of high-end Elf meters

Elf 2

Elf 2 is the next generation of compact and precise Elf meters. It is based on single-jet mechanical flow meters in the second accuracy class (according to PN-EN 1434) and which stands out with its modern design.

Elf 2 has new functions and communication capabilities. It can be used as a heat and cooling meter. It has a dynamic integration period and it is powered by batteries which last for 6 or 12 years of operation. The wide communication capabilities are supported by interchangeable communication modules: RF wireless M-Bus OMS with two pulse inputs, M-Bus with four pulse inputs, M-Bus with two pulse inputs and one pulse output, RS485 with the implemented Modbus protocol.

It is fully compliant with WELMEC 7.2 guidelines to ensure the safety of the measuring instrument software at the same time.

Use

The meter is designed for heating/cooling systems in residential, office, commercial and apartment buildings. Due to its attractive design, the meter fits into any room. It can be used as a heat meter, cooling meter, or heat and cooling meter in one system. It can be mounted horizontally or vertically.

It is perfect for residential heat distribution units (logoterma) thanks to dynamic temperature measurement and integration time (2-6 s).

Thanks to wide communication capabilities, the meter can be used in cable and wireless automatic reading systems as well as in building automation systems.

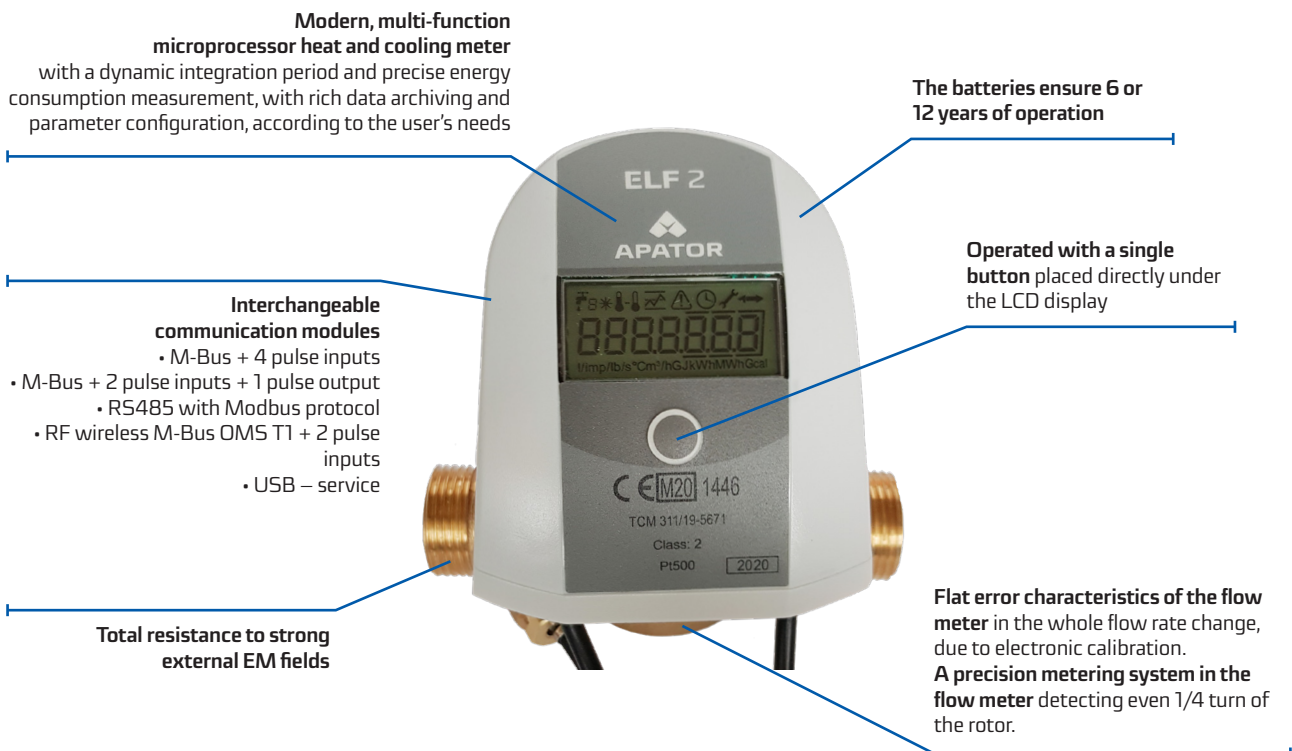

Advantages

- Small dimensions, horizontal or vertical mounting and rotating display, which allows installation and readability in any environment.
- High measurement accuracy, 1:100 measurement dynamics, metrological stability ensures correct and accurate billing of energy consumption.
- Operation in heat, cooling, or heat and cooling systems.
- Versions with different nominal flow rates (0.6, 1.0, 1.5, 2.5 m³/h) and diameters (DN15, DN20) ensures optimum selection for metering any room.
- Dynamic temperature measurement and integration period (2-6 sec) ensures correct energy measurement even under short flows – perfect for residential heat distribution units.
- Battery power for 6 or 12 years of operation – over two validation periods.
- The interchangeable communication modules ensure operation in reading and building automation systems, and allow the connection of four different meters with pulse output to Elf 2 (water meters, electricity meters).
- Extensive archiving capability for measurement data in retentive memory: registers per minute (15-1440 minutes), hour, day, month and year ensures safe measurement data storage and possibility for the complete analysis of meter operation
- Archive register reading and customisation of meter configuration for individual needs with dedicated software

Regulatory and standard compliance

The Elf 2 heat meter meets the requirements of the following standards and directives:

- Directive 2014/32/EU of the European Parliament and of the Council of 26 February 2014 relating to the making available on the market of measuring instruments, with specific consideration to Annex VI (MI-004) – Heat Meters.
- Radio Equipment Directive (RED) 2014/53/EU
- PN-EN-1434 – Heat meters. Parts 1-6.
- PN-EN 61000 – Electromagnetic compatibility (EMC). Parts 2-4.
- PN-EN 13757 – Communication systems for meters and remote reading of meters. Parts 1-4.
- OIML R75
- Type test certificate TCM 311/19 – 5671

Data archiving

Elf 2 data is stored in five types of archive: per minute, hour, day, month, and year. The detailed information about data recording in the archives is shown in the table below.

Table 1. Data archiving

Archive data	Period	Quantity	Properties
Minute*	From 15 min to 1440 min	200 (1.5 days – 5 months)	Recording period configurable by the user
Hourly*	1 hour	744 (month)	Recording on the minute determined by the user
Daily*	1 day	366 (year)	Recording on the hour determined by the user
Monthly	1 month	241 (20 years)	Recording on the day of a month determined by the user, on the hour determined in the daily archive
Annual	1 year	20 (20 years)	Recording on the month determined by the user, on the day of a month determined in the monthly archive, on the hour determined in the daily archive

* data reading from these registers is only digital, from the other registers also on LCD

The following data is stored in the archives:

- heat energy counter
- cooling energy counter
- heat volume counter
- cooling volume counter
- error operating time
- abnormal operating time
- counter for additional input 1
- counter for additional input 2
- counter for additional input 3
- counter for additional input 4
- average power during the period
- average flow during the period
- average supply temperature per period
- average return temperature per period
- maximum power per period*
- minimum power per period*
- maximum flow per period*
- minimum flow per period*
- maximum supply temperature per period*
- minimum supply temperature per period*
- maximum return temperature per period*
- minimum return temperature per period*

* only for monthly and annual records

Meter operation

The heat meter is operated with a single push-button and an LCD. Press push-button shortly to cycle between the successive screens of one menu group; press the push-button longer to enter or exit a menu group.

The display of data on Elf 2 heat meters is divided into five menu groups which correspond to the functionality of the data:

- actual data – group 1,
- monthly registration data – group 2,
- annual registration data – group 3,
- service data – group 4,
- module configuration – group 5,
- global registers – group 6 (optional).

The basic stable state shown on the display is the current heat consumption (group 1).

Heat consumption



LCD Test

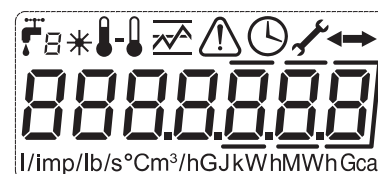

When the button is quickly pressed, the display test appears, which shows all available symbols. When the button is pressed again, it shows the remaining current data.

If the symbol  flashes when displaying the actual data, an error has occurred and the error code is not zero.

If  is displayed, there is flow in the direction of volume and heat counting.

The symbol  means that the current flow direction is wrong. When very small flows occur, the direction symbols will appear shortly.

To change the display group, press and hold the button for two seconds until the group number is displayed. When the button is subsequently pressed, the following messages will be displayed:

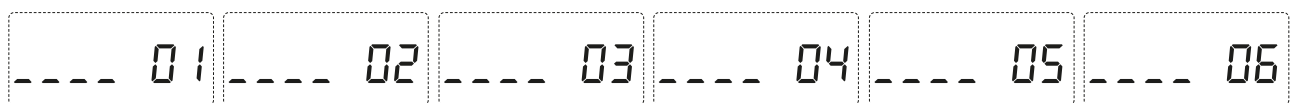

When seen, choose the desired group number and press and hold again until the first value of the selected group is displayed.

The successive values in group 1, 4, 5 and 6 (actual, service, module configuration and global registers) are displayed by repeatedly pressing the button.

When switched to display, the data in group 2 and 3 (registered data), the displayed values cycle every two seconds. The first reading is the message with the number of maximum registrations available in the group. This message is displayed only once for every access to the data group (it does not repeat in cycling).

This reading is followed by a cycled display of successive values in the register; at the beginning, each record shows a message which record will be displayed at a given moment and how many records have been registered. To display the next written record quickly press the push-button.

Communication modules

Elf 2 heat meters have a connector and a socket on the back side of the calculator for communication modules placed in separate housings. The module housings are inserted into the socket and mounted to its housing with two bolts.

The modules form an integral part of the heat meter after the installation. The modules can be installed at any time during the operation of the heat meter, because it can be done without tampering with the validation seals.

Module installation

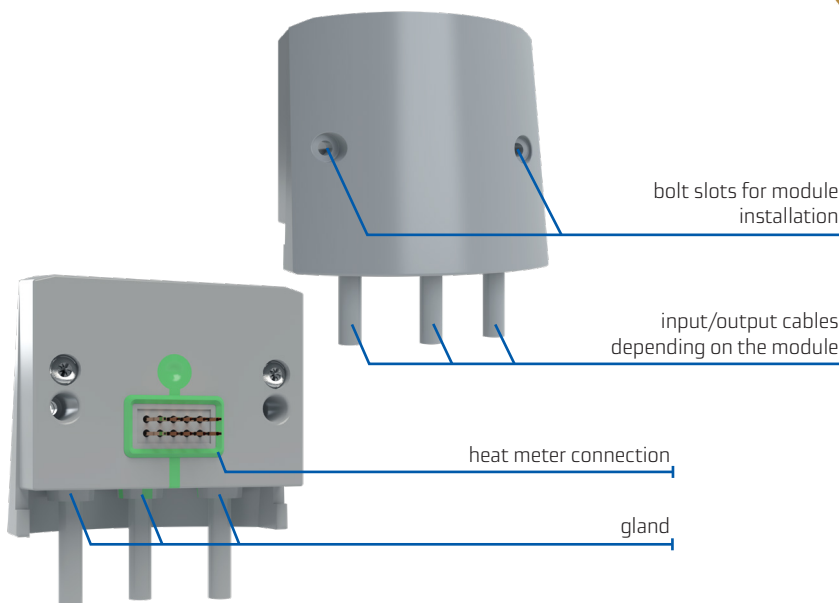
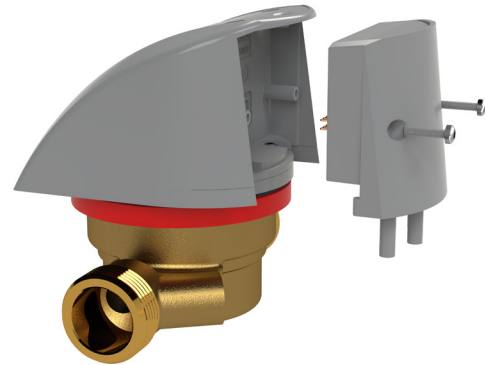

You can choose from the following communication modules:

- M-Bus with 4 pulse inputs
- M-Bus with 2 pulse inputs and 1 pulse output
- RS485 with Modbus implemented
- RF wireless M-Bus OMS T1 with 2 pulse inputs
- USB – service

Technical specifications

Flow transducer			Apator				
Manufacturer mark			JS90-0,6-TI	JS90-1-TI	JS90-1,5-TI	JS90-1,5-G1-TI	JS90-2,5-TI
Nominal diameter	DN	mm	15	15	15	20	20
Minimum volume flow – horizontal arrangement H	q_i	dm ³ /h	6	10	15	15	25
Minimum volume flow – vertical arrangement V	q_i	dm ³ /h	12	20	30	30	50
Nominal flow rate	q_p	m ³ /h	0,6	1,0	1,5	1,5	2,5
Maximum flow rate	q_s	m ³ /h	1,2	2,0	3,0	3,0	5
Starting flow	q_f	dm ³ /h	2,5	2,5	4,5	4,5	7,5
Measurement range q_p/q_i – horizontal arrangement H		-	100				
Measurement range q_p/q_i – vertical arrangement V		-	50				
Maximum permissible error MPE	E_f	%	$E_f = \pm(2 + 0,02 q_p/q)$				
Counter reading range		m ³	10^4				

Flow transducer					
Manufacturer mark		Apator			
Factory mark		JS90-0,6-TI	JS90-1-TI	JS90-1,5-TI	JS90-1,5-G1-TI
Scale interval value		dm ³	1		
Maximum Admissible Operating Pressure		wg bar	PS16, MAP16		
Nominal pressure		PN-EN 1434- 1:2015 bar	PN16		
Maximum pressure loss at q_p		kPa	ΔP 25		
Temperature range limits		°C	$\Theta_{min} = 0,1^\circ\text{C}$ do $\Theta_{max} = 90^\circ\text{C}$		
Flow disturbance sensitivity class acc. to ISO4064-3:2017		-	U0, D0		
Installation position		-	H, V		
Reverse Flow		-	No		
Accuracy class 2 acc. to PN-EN-1434-1:2015		-	Class 2 (H); 3 (V)		
Transducer thread diameter		G	cal G 3/4		G1
Water meter length		L	mm 110		130
Relative humidity		%	≤ 90		
Environmental conditions Class A		Climate	Operation in closed areas Operating temperature range: -5 up to 55°C – low humidity level – normal electric and electromagnetic exposure level – low mechanical exposure level		
		Mechanical	Class M1		
		Electromagnetic	Class E1		

Electronic resolver					
Manufacturer mark		-	Apator		
Energy unit, selectable		-	GJ (standard), kWh albo Gcal		
Display type		-	LCD, 7 digits, height: 7 mm		
Type of resolver fastening to water end		-	Rotary – revolution angle 0 to 360°		
Transducer electronic circuit		-	Integrated with the resolver electronic circuit		
Readings cycling		-	One button		
Auxiliary modules		-	M-Bus, Wireless M-Bus, USB, RS485		
Temperature range limits		wg PN-EN 1434- 1:2015 °C	$\Theta_{min} = 1^\circ\text{C}$ $\Theta_{max} = 105^\circ\text{C}$		
Differential temperature range limits		°C	$\Delta\Theta_{min} = 3^\circ\text{C}$ $\Delta\Theta_{max} = 104^\circ\text{C}$		
Limit MPE		E_c	$E_c = \pm(0,5 + \Delta\Theta_{min} / \Delta\Theta)$		
Temperature sensor		-	Pt500		
Power supply		-	3.6 V lithium battery; 2.6 Ah AA size or 2 × AA size		
Battery life		years	standard 6 (option 12)		
Protection class, IEC-529		IP	IP65		
Ambient temperature		t_a	°C 5 to 55		
Relative humidity		W	% <90		
Weight		kg	0,2		
Serial baud rate		Baud	9600		
Stop bits		-	1		
Data bits		-	8		
Parity		-	Even		
Mean current consumption in the operating/test operating mode		μA	~25/~100		

Resolution of available data	LCD	M-Bus	Archives
Energy	0,001 GJ/ 0,1 kWh/ 0,001 Gcal	0,1 kJ/ 0,01 Wh/ 0,1 kcal	0,1 kJ/ 0,01 Wh/ 0,1 kcal
Volume	0,001 m ³	0,001 m ³	0,001 m ³
Values for additional inputs			
Momentary temperature	0,01°C	0,01°C	-
Instantaneous flow	0,001 m ³ /h	0,001 m ³ /h	-
Instantaneous power	0,1 kW	0,1 kW	-
Average, maximum and minimum temperatures	-	-	0,01°C
Average, maximum and minimum flow	-	-	0,001 m ³ /h
Average, maximum and minimum power	-	-	0,1 kW
Operating time	1h	1h	1h

Temperature sensor pair			
Manufacturer mark	-	Aptor	
Factory mark	-	TOPE 43	
Thermometer resistor	-	Pt500	
Method of connection with the resolver	-	Soldered	
Temperature measurement range	°C	Θ _{min} = 1°C Θ _{max} = 105°C	
Differential temperature range	°C	ΔΘ _{min} = 3°C ΔΘ _{max} = 104°C	
Maximum operating pressure	MPa	1,6	
Maximum measurement current	mA	5	
Sensor wall material	-	Stainless steel, brass	
Outer wall material	-	No outer wall	
Maximum permissible error MPE	E _t	%	E _t = ±(0,5 + 3 * ΔΘ _{min} / ΔΘ)
Connection cables	°C	Length 1.5 m, 2 × 0.25 mm ² , polyurethane insulation	

Communication module M-Bus + 4 pulse inputs		APT-ELF-2-MBUS-1
Housing ingress protection rating		IP65
Pulse inputs		
Maximum voltage		6 V
Maximum current		0,05 mA
Wire insulation voltage rating		> 500 V
Maximum wire length		10 m
Maximum frequency of input pulse		20 Hz
Input pulse duration		50 ms
Input pulse interval		50 ms
Reed relay make input impedance		<10 kΩ
Reed relay break input impedance		>3 MΩ
M-Bus		
Maximum voltage		42 V
Maximum current		2 mA
Wire insulation voltage rating		>500 V
Maximum wire length in network		<1000 m
Communication baud rate with the heat meter		9600 Baud
Maximum cross section of supply wires		2400 Baud
Maximum recommended readout frequency (at 2400 bauds)		900 s
Internal interface register refresh interval		60 s

Communication module M-Bus + 2 pulse inputs + 1 pulse output	APT-ELF-2-MBUS-2
Housing ingress protection rating	IP65
Pulse inputs	
Maximum voltage	6 V
Maximum current	0,05 mA
Wire insulation voltage rating	> 500 V
Maximum wire length	10 m
Maximum frequency of input pulse	20 Hz
Input pulse duration	50 ms
Input pulse interval	50 ms
Reed relay make input impedance	< 10 kΩ
Reed relay break input impedance	> 3 MΩ
Pulse outputs	
Maximum voltage	24 V
Maximum current	10 mA
Voltage drop across optical coupler at I _{max}	1 V
Wire insulation voltage rating	> 500 V
Maximum wire length	10 m
Max frequency	1000 Hz
Minimum pulse duration	250 ms
Minimum pulse interval	7,8 ms
M-Bus	
Maximum voltage	42 V
Maximum current	2 mA
Wire insulation voltage rating	> 500 V
Maximum wire length in network	< 1000 m
Communication baud rate with the heat meter	9600 Baud
Maximum cross section of supply wires	2400 Baud
Maximum recommended readout frequency (at 2400 bauds)	900 s
Internal interface register refresh interval	60 s

RS485 communication module with Modbus protocol	APT-ELF-2-RS485-1
Housing ingress protection rating	IP65
Supply voltage	24 VDC
Current consumption	3 mA
MODBUS	
Address	1-247
Baud rate	300 Baud 600 Baud 1200 Baud 2400 Baud 4800 Baud 9600 Baud 14400 Baud 19200 Baud
Operation mode	RTU with 8e1 frame format RTU with 8n1 frame format
Maximum response start time	125 ms

Register map

Address	Register	Format	Address	Register	Format
1024	Dp positions and main units		1064	Return temperature	Uint32
1026	Factory no.	BCD	1066	Temperature difference	Uint32
1028	Customer number	BCD	1068	Metrological test	Uint32
1030	Primary energy	Uint32	1072	Elf 2 firmware version	Uint32
1032	RTC Time	Uint32unix	1074	Module firmware version	Uint32
1034	Operating time	Uint32 [h]	1532	Type of metering device	Uint16
1036	Error operating time	Uint32 [h]	1535	Error code	Uint16
1038	Cooling energy	Uint32	1538	Power	Uint16
1040	Main energy – fractional part [0.1 kJ]	Uint32	1542	Flow	Uint16
1042	Cooling energy – fractional part [0.1 kJ]	Uint32	1555	Device version	BCD
1044	Primary volume	Uint32	4201	Port configuration	Uint16
1046	Cooling volume	Uint32	4202	Modbus address	Uint16
1062	Supply temperature	Uint32	4203	Module diagnostics	Uint16

RF communication module, Wireless M-Bus + 2 pulse inputs	APT-ELF-2-WMBUS-1
Housing ingress protection rating	IP65
Operating time	Min. 5 years
Power supply	
Power source	CR2z lithium battery
Supply Voltage	3 V
Capacity	1000 mAh
Pulse inputs	
Maximum voltage	6 V
Maximum current	0,05 mA
Wire insulation voltage rating	> 500 V
Maximum wire length	10 m
Maximum frequency of input pulse	20 Hz
Input pulse duration	50 ms
Input pulse interval	50 ms
Reed relay make input impedance	<10 kΩ
Reed relay break input impedance	>3 MΩ
RF communication	
Frequency	868,95 MHz
Communication mode	T1
Data transmission period	15 s
Register refresh rate	900 s
Transmitter power	10 dBm
Transmitted registers	the serial number error flags date heat energy primary volume supply temperature return temperature heat energy for the last month
Range	300 m outdoor

USB – service communication module	APT-ELF-2-USB-1
Housing ingress protection rating	IP65
Data transmission speed	9600 b/s
Power supply	
Power source	Direct from USB interface socket
Voltage	5 V DC
Cable	
Communication connector type	USB A, ver. 2.0
Cable length	1.5 m

Dimensions and pressure loss diagram

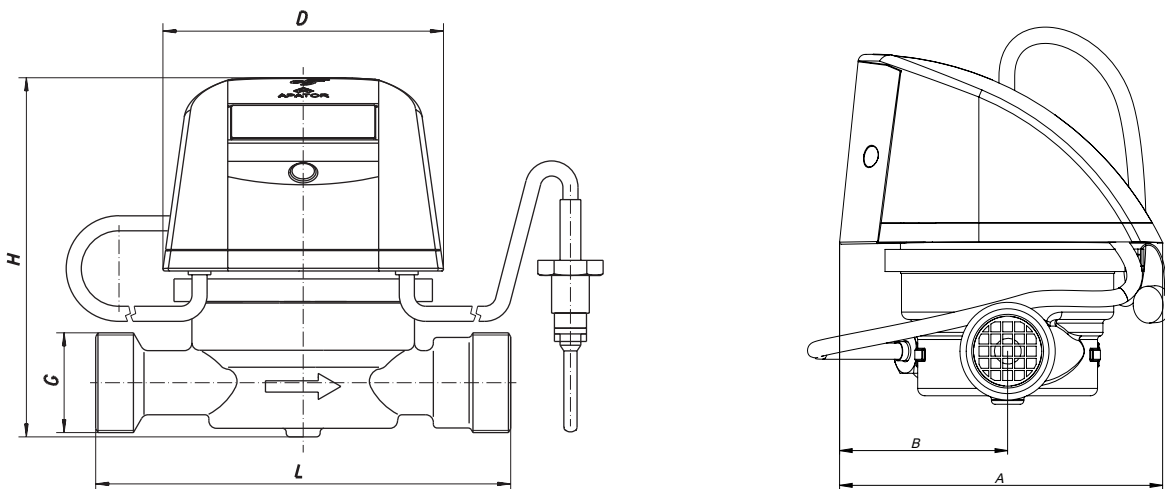

	Dimension	
G	G 3/4	G 1
L	110 mm	130 mm
H	95,5 mm	99,9 mm
A	89,8 mm	89,8 mm
B	46,7 mm	46,7 mm
D	74,4 mm	74,4 mm
Weight	0,6 kg	0,7 kg

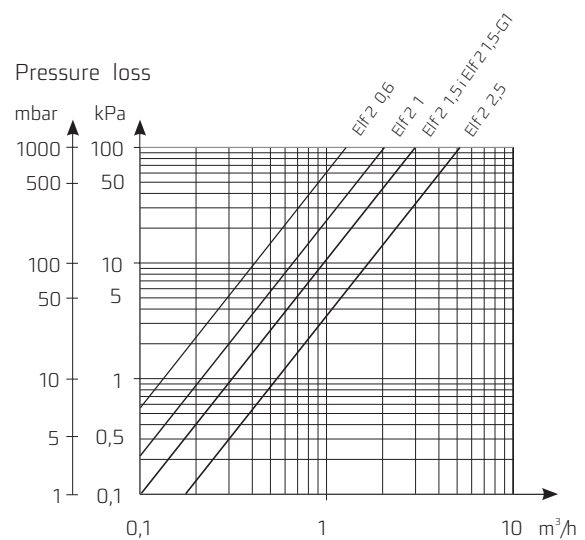

Installation

Sample installation and meter seal on return

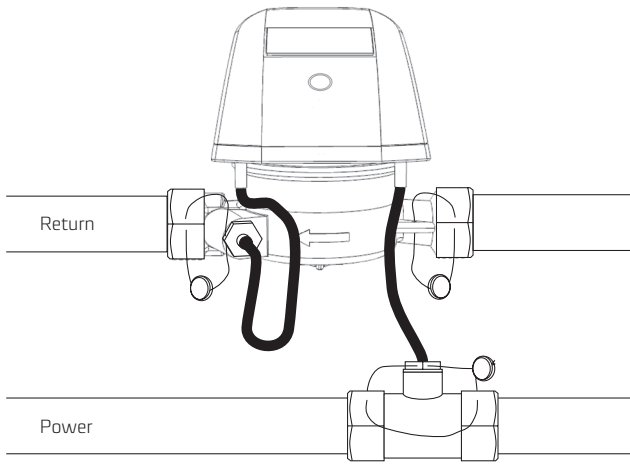

Sample sensor installation in the tee or ball valve

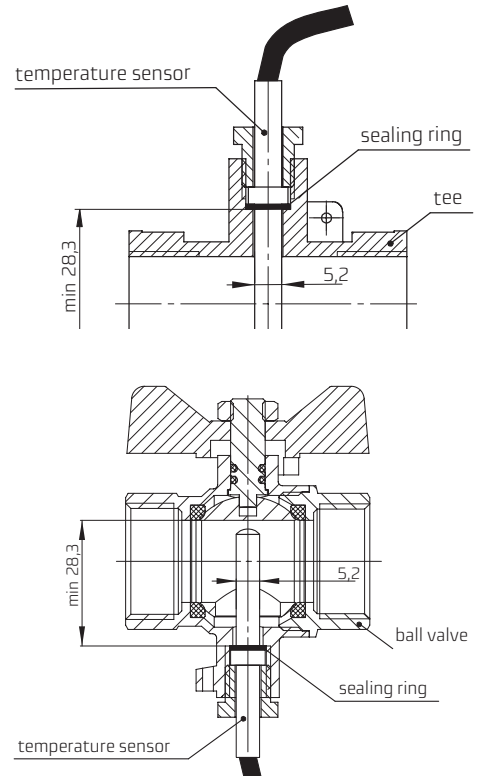

Connection fittings

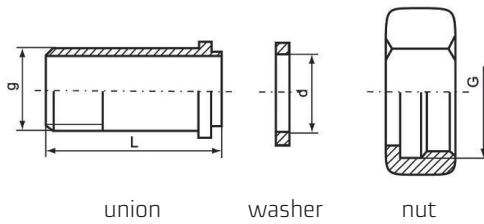

DN	G	g	d	L
	inch	inch	mm	mm
15	3/4	1/2	17	40
20	1	3/4	23	50

Elf 2 – sample order

If you would like to buy the Elf 2 digital heat meter, please give all the necessary technical details according to the following pattern:
(heat meter name) – (flow meter type) – (installation) – (communication model)

For example: An Elf 2 heat meter with JS90-1,5-TI flow meter, supply or return piping installation, M-Bus module with 4 pulse inputs.

Additional equipment – on request:

- ball valves or tees for temperature sensor installation,
- connecting elements for flow meter installation.



The data here is current on the date of issue.

The manufacturer has the right to modify and improve the products without prior notice.

This publication is intended for information purposes only and shall not be construed as a commercial offer under the Polish Civil Code.



Apator Metra
Havlíčkova 919/24, 787 01 Šumperk
phone: +420 583 718 111
cell: +420 777 746 178
fax: +420 583 718 150
e-mail: prodej@metra-su.cz

www.metra-su.cz