



Český metrologický institut

Notified Body No. 1383, Okružní 31

638 00 Brno

EC-TYPE EXAMINATION CERTIFICATE

Number: TCM 142/10 – 4730

Addition 1

This addition replaces all previous versions of this certificate in full wording.

Issued by: **Český metrologický institut**
Okružní 31
638 00 Brno
Czech Republic

Notified Body No. 1383

In accordance with: point 3 of annex 2 to Government Order No. 464/2005 Coll. (annex B of the Directive 2004/22/EC) from 19 October 2005 that lays down technical requirements on measuring instruments and implements in Czech Republic Directive 2004/22/EC of the European Parliament and of the Council.

Manufacturer: **APATOR POWOGAZ S.A.**
(Applicant) **ul. Klemensa Janickiego 23/25**
60-542 Poznań,
Poland

In respect of: **water meter – mechanical, multi jet**
type: WM..
Accuracy class: 2
Temperature class: T30, T50

Valid until: **14 March 2020**

Document number: **0115-CS-A008-10**

Description: Essential characteristics, approved conditions and special conditions, if any, are described in this certificate. This certificate contains 6 pages.

Date of issue: 18 August 2010



RNDr. Pavel Klenovský

Notified Body No.1383

1. Measuring device description

The multi jet, mechanical water meters type WM.. are designed to measure the volume at metering conditions of water passing through the measurement transducer in the sense of the Directive of the European Parliament and of the Council no. 2004/22/EC of measuring instruments, as amended.

The water meters type WM.. consist of a wet measuring section and wet mechanical indicating device. Water flows in the measuring section and rotates the vane wheel of transducer. The rotation is transmitting to the system of gear wheels to register. The register consists of five or six rollers and four pointers. The measuring section and wet mechanical indicating device are connected to meter body by cover with screw. The adjustment of the water meter is executed by turn of adjusting screw.

The water meter shall be installed to operate in horizontal position only.

There is version NK with reed contact pulse transmitter and version NKP with preequipped for later installation of pulse transmitter and remote reading device – for example radio module. These remote reading devices are not covered by this certificate. There is a one pointer with magnet in the counting mechanism in the both version NK and NKP.

Water meters are manufactured according to technical documentation of the company APATOR POWOGAZ S.A., No. 60-9614-000000 for type WM2,5; No. 60-9624-000000 for type WM4; No. 60-9627-000000 for type WM6,3; No.60-9634-000000 for type WM10; No. 60-9637-000000 for type WM16.

2. Basic technical data

Meter type	WM2,5	WM4	WM6,3	WM10	WM16
Nominal diameter DN [mm]:	15 / 20	20	25	25 / 32	40
Minimum flowrate Q_1 [m ³ /h]:	0.016	0.025	0.039	0.063	0.10
Transitional flowrate Q_2 [m ³ /h]:	0.025	0.040	0.063	0.10	0.16
Permanent flowrate Q_3 [m ³ /h]:	2.5	4.0	6.3	10	16
Overload flowrate Q_4 [m ³ /h]:	3.13	5.0	7.88	12.5	20
Ratio Q_2 / Q_1 :	1.6				
Ratio Q_3 / Q_1 :	160				
Accuracy class:	2				
Orientation limitation:	Horizontal				
Maximum permissible error (MPE) lower flow range:	± 5 %				
Maximum permissible error (MPE) upper flow range:	± 2 % for water having a temperature ≤ 30 °C ± 3 % for water having a temperature > 30 °C				
Temperature class:	T30, T50				
Maximum admissible temperature [°C]:	30, 50				
Water pressure classes:	MAP 16				
Maximum admissible pressure [MPa]:	1.6				
Pressure-loss classes (ΔP) [kPa]:	63				40
Total length [mm]:	165 or 190	190	260	260	300
Indicating range [m ³]:	99 999				999 999
Resolution of the indicating device [dm ³]:	0.05				
Resolution of the indicating device for rapid testing [pulse / dm ³]:	118.642	90.0	62.3077	23.1429	12.4615
Flow profile sensitivity classes:	U0, D0				
Connection type: Screw thread	G¾ / G1	G1	G1¼	G1¼ / G1½	G2
Reed contact K-factor [pulse / L]:	0.25; 0.5; 1; 2.5; 5; 10; 25; 50; 100; 250; 500; 1000				
Reed contact power supply (U_{max} / I_{max}):	max. 24 V / 0.1 A				

3. Test

Technical tests of the WM2,5; WM4; WM6,3; WM10 and WM16 water meters were performed in compliance with the International Recommendation OIML R 49 Edition 2006 (E) with conformity to EN 14154:2005, Test Report No. 6015-PT-P045-10 from July 9. 2010.

4. The measuring device data

There are following data on the measurement device:

- The "CE" marking and supplementary metrology marking
- Number of EC-type examination certificate
- Name or trademark of manufacturer
- Year of manufacture (last two digits)
- Measuring device type
- The serial number (as near as possible to the indicating device)
- Unit of measurement (m^3)
- Accuracy class 2
- Numerical value Q_3 in m^3/h ($Q_3 \times \times$)
- The ratio Q_3 / Q_1 , ($R \times \times$)
- The maximum admissible pressure ($\times \times$ MPa or $\times \times$ bar)
- The temperature class ($T \times \times$)
- The maximum pressure lost ($\Delta P \times \times$)
- Classes on sensitivity to irregularities in velocity field (U0 D0)
- Direction of flow arrow on both sides of the meter body

and if the water meter is equipped with impulse transmitter:

- Output signals for ancillary devices (type / levels)
- External power supply requirements (voltage – frequency)

5. Sealing

The connection of water meter screw cover with of adjusting screw, and connection of water meter body and reed impulse transmitter if any has to be sealed.

The location of the seal is described in Figure 1.

Figure 1: The sealing of water meters type WM:

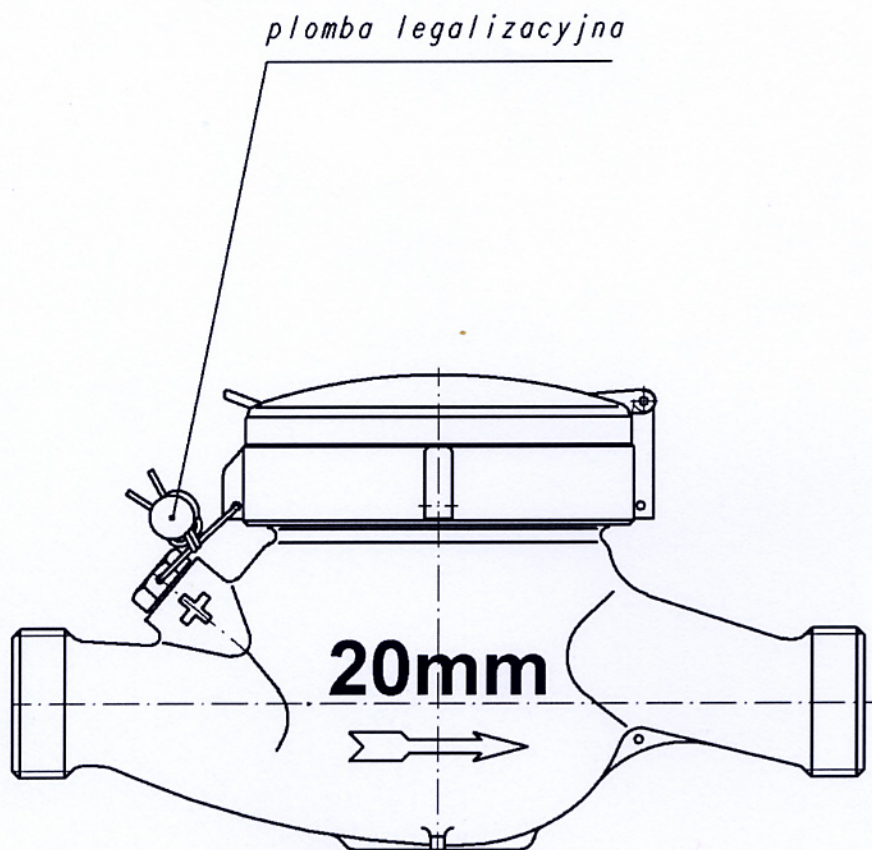

Figure 2: The water meter type WM:

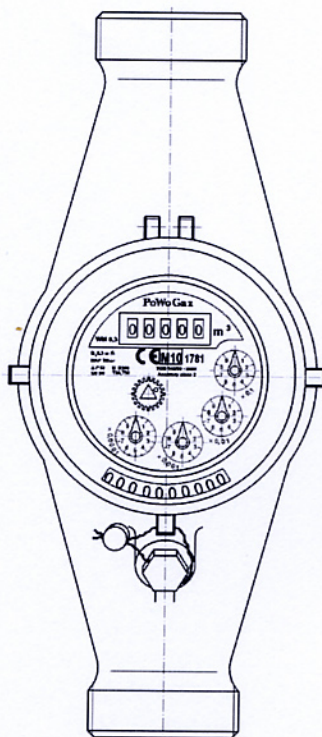

Figure 3: The water meter type WM-NK:

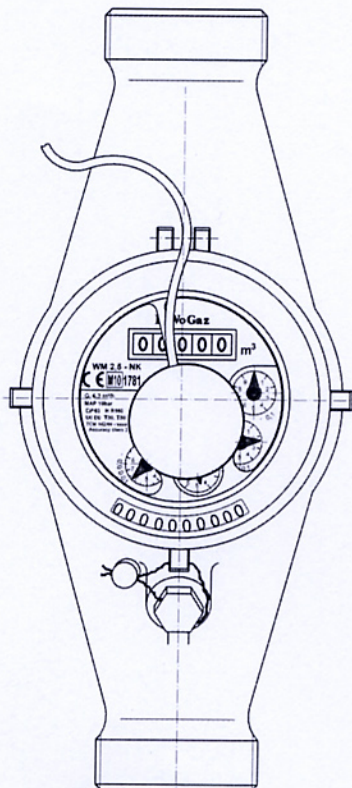
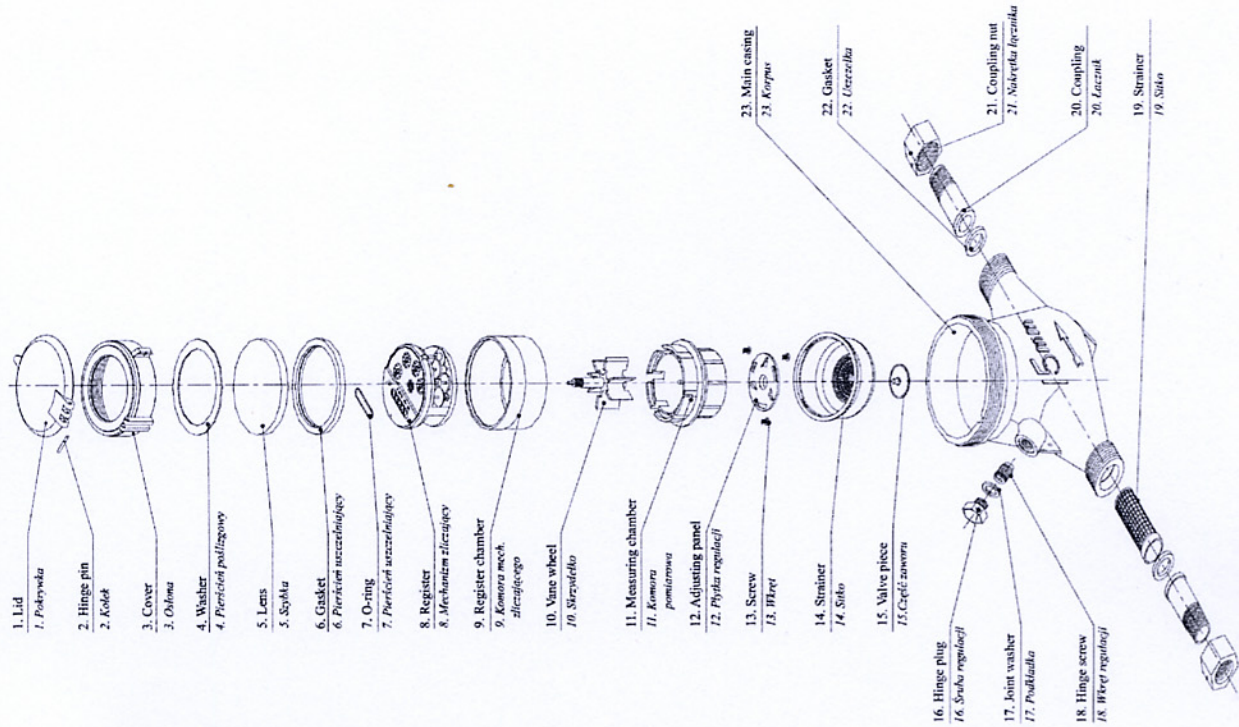

Figure 4: The assembling of water meters type WM:

Wodomierz wielostrumieniowy makrobieżny - WM
(APATOR POWOGAZ S.A.)
CZĘŚCI ZAMIENNE



WODOMIERZ WIELOSTRUMIENIOWY MOKROBEŻNY - WM
(APATOR POWOGAZ S.A.)
CZĘŚCI ZAMIENNE
MATERIALS
MATERIALY

CODE Nr części	DESCRIPTION Opis	MATERIALS Materiály
01	LID Pobrywka	ABS
02	HINGE PIN Kośki	H62 BRASS Mosiądz
03	COVER Osłona	ZHP6S9-1 PE
04	WASHER Pierścień uszczelniający	Politylen
05	LENS Szyba	GLASS Szkło
06	GASKET Pierścień uszczelniający	NITRILE RUBBER Guma
07	O-RING Pierścień uszczelniający O-ring	NITRILE RUBBER Guma
08	REGISTER Mechanizm zliczający	ABS, POM, LCI18N9 Terpolimerakrylonit, Poliacetal, Sól alirizyczna
09	REGISTER CHAMBER Komora mechaniczno-zliczającego	ABS Terpolimerakrylonit
10	VANE WHEEL Śrzedzisko	ABS Terpolimerakrylonit
11	MEASURING CHAMBER Komora pomiarowa	ABS Terpolimerakrylonit
12	ADJUSTING PANEL Płyta regulacji	ABS Terpolimerakrylonit
13	SCREW Wkręt	H62 BRASS Mosiądz
14	STRAINER Siatka	PE Politylen
15	VALVE PIECE Część zaworu	ABS, H62 BRASS Terpolimerakrylonit, Mosiądz
16	HINGE PLUG Wkręt regulacji	POM
17	JOINT WASHER Podkładka	PE Politylen
18	HINGE SCREW Śruba regulacji	ZHP6S9-1 Mosiądz
19	STRAINER Siatka	PE Politylen
20	COUPLING Łącznik	HP6S9-1 Mosiądz
21	COUPLING NUT Nakrętka łącznika	ZHP6S9-1 Mosiądz
22	GASKET Uszczelnienie	NITRILE RUBBER Guma
23	MAIN CASING Korpus	ZHP6S9-1 Mosiądz