



**ELECTRONIC HEAT COST ALLOCATOR
WITH INTEGRATED RADIO TRANSMITTER**

E-ITN 30.6

Installation and service manual

APATOR METRA s.r.o.

Havlíčková 919/24

787 64 Šumperk

tel.: +420 583 718 111

fax: +420 583 718 150

e-mail: prodej@metra-su.cz

www: <http://www.metra-su.cz>

TABLE OF CONTENTS

1. INTRODUCTION.....	4
1.1. LC Display.....	4
2. DEVICE DESCRIPTION.....	5
3. TECHNICAL SPECIFICATIONS.....	6
3.1. Design.....	8
4. OPERATION MODES.....	9
4.1. Operation modes.....	9
4.2. Submenu navigation.....	9
4.3. Sleeping mode.....	9
4.3.1. Submenu structure in sleeping mode.....	9
4.3.1.1. Activation of working mode.....	10
4.3.1.2. Allocator self test.....	10
4.3.1.3. Setting of radiator type.....	10
4.3.1.4. Accuracy test of sensors.....	10
4.4. Mode of waiting for start date.....	11
4.4.1. Submenu structure in mode of waiting for start date.....	11
4.5. Working mode.....	11
4.5.1. Menu structure in working mode.....	11
4.5.1.1. Value for current year billing period.....	12
4.5.1.2. Value for the previous year billing period.....	12
4.5.1.3. Value for current month billing period.....	12
4.5.1.4. Value for the previous year billing period.....	12
4.5.1.5. Serial number.....	12
4.5.1.6. Temperature of the radiator sensor.....	12
4.5.1.7. Temperature of the ambient temperature sensor.....	12
4.5.1.8. Date/day of the yearly/monthly billing period beginning.....	12
4.5.1.9. Current date.....	12
4.5.1.10. Current time.....	12
4.5.2. Structure of submenu in the working mode of the allocato.....	13
4.5.3. Structure of submenu with month values.....	13
4.5.4. Last year of battery life.....	13
4.6. Setting of parameters.....	13
4.6.1. List of the programable parameters of heat cost allocator E-ITN 30.6.....	14
4.7. Error mode.....	14
5. OTHER INFORMATIONS.....	15
5.1. Electronic seal reactivation.....	15
5.2. Transportation.....	15
5.3. Storage.....	15
5.4. Application and disposal.....	16
5.5. Defects and their elimination.....	16
5.6. Warranty.....	16
6. ACCOMPANYING DOCUMENTATION.....	17
6.1. Ordering.....	17
6.2. Packing.....	18
7. INSTALLATION METHODS.....	21
7.1. Allocator installation.....	21
7.2. Allocator back plate.....	21
7.3. List of installation material.....	22
7.4. E-ITN 30 mounting place on segmented and panel radiators.....	23
7.4.1. Vertical position:.....	23
7.4.2. Horizontal position:.....	23
7.5. Installation on segmented radiators.....	24

7.5.1. Description of installation.....	24
7.5.2. Installation differences.....	25
7.6. Installation on panel radiators.....	26
7.6.1. Description of installation	26
7.7. Installation on horizontal and vertical registers.....	28
7.7.1. Installation description.....	28
7.7.2. Proper E-ITN 30 installation on different register types.....	29
7.8. Model No. 1 – Cast iron radiators.....	31
7.9. Model No. 2 – Cast iron radiators with flat vertical front panel.....	32
7.10. Model No. 3 – Cast iron radiators with distance pad.....	33
7.11. Model No. 4 – Steel radiators.....	34
7.12. Model No. 5 – Steel radiators with distance pad.....	35
7.13. Model No. 6 – Panel radiators with shaped front side.....	36
7.14. Model No. 7 – Panel radiators with a flat front panel.....	37
7.15. Model No. 8 – Tubular radiators - ladder.....	38
7.16. Model No. 9 – Tubular radiators – ladder with oval base.....	39
7.17. Model No. 10 – Radiators made from smooth or ribbed tubes - register.....	40
7.18. Patter No. 11 – Aluminium radiator with vertical ribs.....	41
7.19. Model No. 12 – Aluminium radiator with vertical ribs.....	42
7.20. Model No. 13 – Radiator JAGA TEMPO.....	43
7.21. Model No. 14 – Radiators Koratherm horizontal K22HM.....	44
7.22. Model No. 15 – Radiators OT Korál.....	45
7.23. Model No. 16 – Koratherm Vertikal K20 V	46

1. INTRODUCTION

E-ITN 30.6 is modern electronic device intended for ratio based allocation of heat cost in buildings with central heating system. The heat cost allocator E-ITN 30 uses the two-sensor measuring principle – integrates temperature difference between sensor of radiator surface temperature and sensor of surrounding temperature.

E-ITN 30 is intended to be installed in one-tube horizontal/vertical and two-tube heating systems with the lowest mean design heating medium temperature $\geq 35\text{ }^{\circ}\text{C}$ and highest mean design heating medium temperature $\leq 105\text{ }^{\circ}\text{C}$.

Each radiator in billing (account) unit with common invoicing heat meter must be equipped with a heat cost allocator of the same type. Technical conditions of heating system must be fulfilled when using heat cost allocators E-ITN 30.

E-ITN 30 is not intended for heat cost allocation for floor heating systems, ceiling radiant heating, flap controlled radiators, radiators with fan, systems with steam heating medium, air heaters and single tube radiators if exceeds the scope of one user. It must not be also used for heating elements that shape and design does not allow reliable transfer of heat to heat cost allocators.

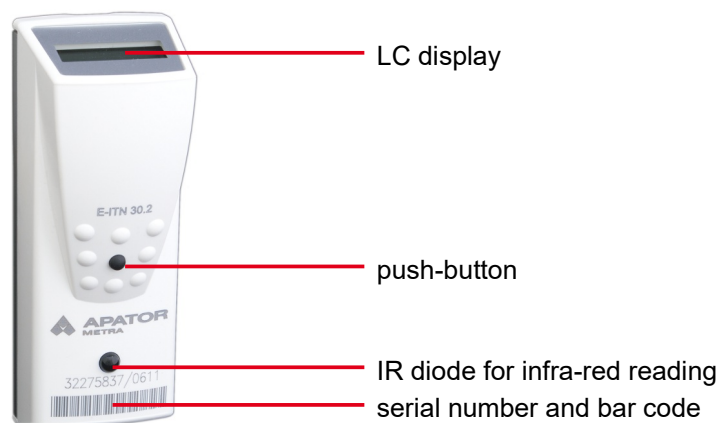

Illustration 1: E-ITN 30

1.1. LC DISPLAY

Basic allocator status and measured values can be displayed on LCD. LCD can display five alphanumeric characters. These values are highlighted by underline and overline, e.g. oPEn.

Meaning of some values may be different if the additional symbol „SM“ at the right bottom corner is displayed. These values are mentioned with „SM“ symbol in text , e.g. 385 SM.

The last symbol on the display indicate end of the battery life, see chapter 4.5.5. Last year of battery life.



Illustration 2:LC Display

To save the battery, after longer period of inactivity (approx. 1 min.), energy-saving mode is activated and display is switched off. Display can be activated by pushing the button. (Illustration 1: E-ITN 30).

When pushing the button briefly, notice ---- on the display will appear. If the button is not pushed in 1 minute, the display will switch off.

The data displayed on the LCD display may vary depending on the type of the allocator and also on the active operating mode. For more information, see below.

2. DEVICE DESCRIPTION

Installation of allocator consists only from mounting of base plate from aluminium alloy and placing of allocator to this base plate. Due to integrated radio transmitter, presence of flat occupant is not required when data are read. No strangers also enter the flat.

Measured data are transmitted in a short ~ 5 ms radio telegrams in the intervals as listed in chapter 3. Technical specification. Time interval between transmissions is not constant – is changed randomly in time frame. So the situation when it would be impossible to read data (in reasonable time) from allocators transmitting in the same time is prevented.

Allocator is equipped with mechanic and electronic seal and is delivered in sealed state with activated electronic seal. In the case of unauthorized removing of base plate, the allocator saves the date of breach of the electronic seal to its memory and stop to show measured data on the display. Only the notice oPEn is displayed and indicates breach of the electronic seal, but allocator continues in measuring and transmitting of measured data. Information about breach of the electronic seal is available in data transmitted by radio module and in data transferred via IR interface.

Notice oPEn will disappear when electronic seal is activated again with reading unit IRU 10.00 via infra-red interface.

The device is resistant against cheating. If any cheating is detected, allocator switches to the mode inconvenient for the user – after cheating is finished, the allocator switches to standard mode.

Allocator is equipped with individual scale. For proper evaluation of measured data, it is necessary to set:

- radiator type (T_{OT})
- radiator nominal output (M)
- evaluation coefficient (K_C) describing heat contact with sensor of radiator temperature

Parameter can be set by manufacturer or before installation with *Programming unit for changing allocator parameters of E-ITN 20.x, 30.x* connected to PC. Radiator type (T_{OT}) can be set in sleeping mode by pressing the button. Billing period is year and month.

3. TECHNICAL SPECIFICATIONS

Communication protocol	W-MBUS dle ČSN EN 13757-4
Application	$t_{\min} \geq 35 \text{ °C}$ (min. temperature of the heating medium) $t_{\max} \leq 105 \text{ °C}$ (max. temperature of the heating medium)
Mode	T1
Measuring principle	two-sensor measuring principle
Conditions for registration	sensor temperature of the radiator $\geq 23 \text{ °C}$ temperature difference between the mean heating medium temperature and the reference air temperature $\leq 5\text{K}$ (according to standard EN 834:2013), different conditions for registration in the summer period
Billing period	yearly and monthly
Resulting rating factor K	individual scale
Calendar functions	<ul style="list-style-type: none"> - Current, previous and penultimate year consumption values - Monthly consumption values for current month + 11 months back - Maximum monthly temperatures of the radiator for current the month + 11 months back - Minimum monthly temperatures of the radiator (current month +11 months back) - Average monthly temperatures of the radiator (current month + 11 months back) - The number of days in month when the allocator was in operation, for current the month + 11 months back (as the day of operation counts a day during which there was at least one increase of consumption value) - Average monthly temperatures of the ambient sensor for current the month + 11 months back
Display	5 digits LCD + 2 special symbols
Protection against cheating	continuous control, if thermal influence is detected, allocator is switched to single-sensor mode mechanical seal with billing company label electronic seal – records manipulation date when uninstalled
Data backup	daily backup of measured values including real time
Function control	automatic, can be activated and controlled by user
Dimensions	100 x 37 x 33 mm
Power supply	lithium battery 3,0 V
Material	ABS + PC / AI – F22

IP code	IP 42
Conformity	ČSN EN 834
Operating frequency	868.95 MHz
Transmitting power	< 5 mW
Class of working cycle	1 (duty cycle percentage <0,1 %)
Transmission length	<p>~ 4,5 ms (basic data format without encryption)</p> <p>~ 4,8 ms (basic data format with AES 128 encryption)</p> <p>~ 6,2 ms (extended data format without encryption)</p> <p>~ 6,7 ms (extended data format with AES 128 encryption)</p>
The frequency of transmission:	<ul style="list-style-type: none"> • Basic data format • ~ 44 [s] for 30 days from the beginning of a billing year • ~ 44 [s] for 6 days from the beginning of a billing month • ~ 720 [s] in summer heating period (at least 3 months) • ~ 250 [s] on other days of year without data encryption • ~ 412 [s] on other days of year with data encryption • Extended data format • ~ 44 [s] for 30 days from the beginning of a billing year • ~ 44 [s] for 3 days from the beginning of a billing month • ~ 720 [s] in summer heating period (at least 3 months) • ~ 318 [s] on other days of year (without data encryption) • ~ 480 [s] on other days of year (with data encryption)
Transmission range	<p>up to 250 m (outside the building, with additional panel antenna)</p> <p><i>Rem.: all metal parts of construction (switch rooms, armouring, lifts, etc.) can negatively affect the range of radio signal.</i></p>
Data coding	Optional AES128
Data available via radio interface without ciphering	<p>Basic data format:</p> <ul style="list-style-type: none"> • reading date • serial number • remote sensor present • value for the current yearly billing period • value for the last yearly billing period • value for the current monthly billing period • value for the last monthly billing period • date of violating the electronic seal • average surrounding temperature for the last billing period <p>Extended data format:</p> <ul style="list-style-type: none"> • reading date • date of the beginning of the billing period • serial number • remote sensor • value for the current yearly billing period • value for the last yearly billing period

	<ul style="list-style-type: none"> • value for the current billing month • value for the last billing month • date of violating the electronic seal ⁽²⁾ • values for the current and last 8 billing months • overall evaluation factor $K = K_c \cdot K_q$
<p>Data available via infra-red interface (for exact data structure see manual for decoding software)</p>	<ul style="list-style-type: none"> • serial number • date of billing period beginning • remote sensor • reading date • values for the current and last two billing years • values for the current and last 11 billing months • max. radiator temperatures for the current and last 11 billing months • min. radiator temperatures for the current and last 11 billing months • average radiator temperatures for the current and last 11 billing months • number of heating days for the current and last 11 billing months ⁽¹⁾ • dates of the allocator electronic seal violation • dates of the remote sensor electronic seal violation • average ambient temperature for the current and last 3 months • radiator type T_{OT} • evaluation factor K_q for radiator output • evaluation factor K_c for the thermal contact of the sensors • transmission format

3.1. DESIGN

Electronic heat cost allocator E-ITN 30 complies with ČSN EN 834.

Allocator consist of cover and printed circuit board covered with mounting plate. Mounting plate is bolted with cover and secured with latch and seal..

Cover, mounting plate, latch and seal are made from plastic material. There are marked values of the lowest and highest heating medium temperature, manufacturer's mark, type of the allocator, serial number (both as number and bar code) and optionally the partner's mark on the cover. The base plate is made of aluminium alloy to ensure of a good thermal contact with the radiator.

To install the heat cost allocator, place it at the upper end of the aluminium back plate, push down so that the locks in the housing fit in the aluminium back plate and push the bottom part of allocator towards back plate. Allocator is fastened to back plate by latch and seal. Now the heat cost allocator can only be uninstalled after breaking the seal.

Device has an electrical circuitry with a 16-Bit microprocessor with extremely low current consumption, is equipped with radio transmitter and powered by lithium battery. The accuracy of the measuring circuit is independent of the battery voltage. The LCD-display has 5 large main digits separated by dots and contains two additional special symbols.

4. OPERATION MODES

4.1. OPERATION MODES

The allocator can be in four operation modes:

- sleeping mode
- mode of waiting for start date
- working mode
- error mode

4.2. SUBMENU NAVIGATION

The allocator contains a simple submenus (depending on current operation mode), that allow to obtain additional informations or perform other activities.

To switch between individual items of menu, push the button briefly. To enter the submenu, choose relevant item and hold the button (approximately 2 seconds) until --A-- appears on LCD. When you release the button, designation of the 1st submenu item appears. Move in menu by short presses of the button. If the button is not pushed for 20 seconds, the LCD returns to the main menu.

Activation process of item is the same as entering the submenu. Find the relevant item and hold the button (for approximately two seconds), till notice --A-- on the LCD appears.

Movement in options is the same – briefly press the button. Selected option confirmation as well – by long (approx. 2 s) press of the button, till notice --A-- appears on LCD.

4.3. SLEEPING MODE

Allocator consumption is reduced to a minimum since no measuring and no calculations are carried out and furthermore allocator does not transmit the data. Sleeping mode is suitable for prolonged storage prior to allocator use. The storage period should not exceed one year.

In sleeping mode allocator allows the following operations:

- display the set parameters (type of radiator, heat output of the radiator, coefficient)
- setting of radiator type
- activation of the working mode of the allocator
- allocator self test
- accuracy test of sensors

Sleeping mode is indicated with notice uPr on the display. If the display does not show any value or notice (due power saving), press the button briefly to switch LCD on. Pressing of the button is indicated by a sign ---- appearing on the display. The device automatically switch the value s ever 2 seconds and

4.3.1. Submenu structure in sleeping mode

When notice uPr appears, hold the button till notice --A-- is displayed and indicates submenu activation. Submenu activation and navigation in the items is described in chapter 4.2. Submenu navigation.

Table 1: Submenu structure in sleeping mode, type E-ITN 30.3

Radiator type (e.g. 2)	<u>tot 2</u>
Heat output of the radiator (e.g. 5000 W)	<u>5000</u>
Coefficient K_{CHF} (e.g. 1.050)	<u>1.050</u>
Setting of radiator type	<u>ntt</u>
Activation of working mode	<u>Act</u>
Allocator self test	<u>ti</u>
Accuracy test of sensors	<u>tPr</u>

4.3.1.1. Activation of working mode

If the allocator is in a sleeping mode, working mode can be activated using button. For activation of working mode, submenu item Act is used.

Working mode activation:

1. Switch to submenu in sleeping mode.
2. When notice Act appears, press and hold the button till notice --A-- is displayed. When you release the button, first menu item is displayed: chapter 4.5.1. Menu structure in working mode.

4.3.1.2. Allocator self test

Allocator self test is used for control of all LCD segments and to test A/D converter for temperature measurement. We can run the test in sleeping mode, working mode and also in mode of waiting for start date. Option is located in submenu whose activation was described above.

To start the test:

1. Switch to submenu item marked as tī (allocator test) with brief press of the button.
2. While tī is displayed, press and hold the button, till notice --A-- appears.
3. Allocator self test has three phases. 1st phase: all segments are turned on . 2nd phase: radiator temperature is displayed, e.g. 36.4°C and in 3rd phase surrounding temperature appears. e.g. 25.4°C SM. Every value is displayed for 2 seconds and LCD is automatically switched into the main menu when self test is completed.

If A/D converter malfunction is detected, allocator switches to fault mode and notice Error is displayed on LCD.

4.3.1.3. Setting of radiator type

Switch to the submenu in sleeping mode. Switch to submenu 4th item marked as ntt (radiator type setting) with button short presses. While ntt is displayed, press and hold the button, till notice --A-- appears. After button release, notice ot x is displayed (number „x“ indicates the selected type of radiator).

Press the button briefly to browse in radiator types and than choose the right one. Confirm selected type of radiator with long press (hold the button till --A-- is displayed). After button release submenu item tot x appears (number „x“ gives us selected type of the radiator).

Table 1: Radiator setting – options

Steel plate radiator with vertical offsets	<u>ot 0</u>
Steel plate radiator with smooth front panel	<u>ot 1</u>
Steel segmented radiator	<u>ot 2</u>
Cast iron segmented radiator	<u>ot 3</u>
Universal (average value 0 to 3)	<u>ot 4</u>
Jaga convector TEMF 030/90/11 or TEMF 040/110/10	<u>ot 5</u>

4.3.1.4. Accuracy test of sensors

The accuracy test of the sensors serves to checking the accuracy of the temperature sensors on the allocator. It can be activated by the „tPr „item of the submenu, which is only available in Sleeping mode.

To start the test:

1. By short presses of the button switch to the 6th item of the submenu marked as „tPr “ (accuracy test of sensors).
2. as the sign „ tPr “ is displayed, press the button and hold until a sign „- A- -“ indicates the activation of the test.

3. When the test has started, the display shows in 6 s intervals the temperature on the radiator sensor (e.g., 42.25°) and the temperature on the ambient temperature sensor (e.g., 35.48°_{SM}) accurate to to decimal places [°C]. The display of the allocator remains switched on, i.e. it is not switched off after a certain time interval. Microprocessor makes the temperature measuring every 30 s.

4.4. MODE OF WAITING FOR START DATE

This mode is suitable when you require to start multiple allocators on the same date. In this mode, the allocator regularly updates real time and compares current date with start date. When the start date is reached, the allocator will start measuring (switch to working mode).

Mode of waiting for start date is indicated with notice: e.g. o 1.12. (date indicates the date of start). If the display does not show any indication (because of power saving), press the button briefly to switch it on.

In mode of waiting for start date, following actions can be performed:

- allocator self test
- displaying of: set radiator type, nominal radiator power and coefficient K_{CHF} (E-ITN 30.3 only)

4.4.1. Submenu structure in mode of waiting for start date

For submenu activation and navigation between items see chapter 4.2. Submenu navigation. Allocator self test activation is described in chapter 4.3.1.2. Allocator self test. Radiator type selection E-ITN 30.3 is described in chapter 4.3.1.3. Setting of radiator type .

Table 2: Submenu structure in mode of waiting for start date

Radiator type (e.g. 2)	<u>tot 2</u>
Heat output of the radiator (e.g. 5000 W)	<u>5000</u>
Coefficient K_{CHF} (e.g. 1.050)	<u>1.050</u>
Allocator self-test	<u>ti</u>

4.5. WORKING MODE

In working mode, allocator performs temperature measurement, calculates the increase of valuecal (if measurement conditions are met), transmits measured data, updates real-time and makes some other actions in regular intervals.

4.5.1. Menu structure in working mode

If nothing is displayed press the button briefly.

Table 3: Submenu structure in working mode

Value for current year billing period	<u>245</u>
Value for previous year billing period	<u>458 SM</u>
Value for current month billing period	<u>...5.8.</u>
Value for previous month billing period	<u>.2.1.5.8.SM</u>
Serial number – first part	<u>-3600</u>
Serial number – second part	<u>0060-</u>
* Radiator temperature	<u>53.3°C</u>
* Surroundings temperature	<u>26.7°C SM</u>
* Date of billing period beginning	<u>U 1.12.</u>
* Current date	<u>10.12.</u>
* Current time	<u>12-45</u>

Note: menu items marked as * are optional, see chapter Chyba: zdroj odkazu nenalezen.
Chyba: zdroj odkazu nenalezen.

4.5.1.1. Value for current year billing period

Value for current year billing period is displayed as 389 (without insignificant zeros). It is calculated from the beginning of the current billing period.

4.5.1.2. Value for the previous year billing period

Value for the last billing period is displayed as 3258 SM. Transfer of measured value for actual billing period to value for the last year billing period is performed, when new year billing period is achieved in 00:00:00.

4.5.1.3. Value for current month billing period

Value for current year billing period is displayed as 389 (without insignificant zeros). It is calculated from the beginning of the current billing period.

4.5.1.4. Value for the previous year billing period

Value for the last billing period is displayed as 3258 SM. Transfer of measured value for actual billing period to value for the last year billing period is performed, when new year billing period is achieved in 00:00:00.

4.5.1.5. Serial number

Serial number is 8 digit figure and it is also labeled on the cover. Serial number is divided in two parts. E.g. serial number „32000015“ is displayed as figure 3200 and 0015. Symbol „ - “ distinguish between first and second part of the serial number.

4.5.1.6. Temperature of the radiator sensor

Temperature of the radiator sensor is displayed as 45.9°C with accuracy of one decimal place.

4.5.1.7. Temperature of the ambient temperature sensor

Temperature of the surroundings sensor is displayed as 26.7°C SM with accuracy of one decimal place.

4.5.1.8. Date/day of the yearly/monthly billing period beginning

Beginning of the billing period is displayed as 1.10 (year versions) or as dF 15 (month versions). After the date is reached, allocator transfers value for current year billing period to value for last year billing period at 00:00:00.

When the date of the billing period is reached at 00:00:00, the allocator transfers the consumptions values for months -1 to -10 to months -2 to -11, consumption value for the current month billing . Period is transered into consumption value for the last billing period and also the consumption value for the current month is added to the consumption value for the monthly biling periods from the current year billing period beginning. Finally, the consumption value for the current month is reset to zero.

Beginning of the billing period can be set by manufacturer or with *Programming unit for changing allocator parameters of E-ITN 20.x, 30.x* connected to PC or notebook to any required date. As a date of the yearly billing period beginning can be set any month in the year, the day must be in the interval <1; 28>.

4.5.1.9. Current date

Current date is displayed as 3.12. Calendar takes leap years into account.

4.5.1.10. Current time

Current time is displayed in 24 cycle, e.g. 08-56 (8:56 AM). Summer time is not distinguished.

4.5.2. Structure of submenu in the working mode of the allocator

Enter submenu from the main menu. When the display is on and 1st menu item is displayed (value for the current billing period, e.g. 389), press and hold the button, till notice --A--, is displayed. After releasing the button, 1st submenu item du is displayed (month values).

Table 4: Submenu structure in working mode

Month values	<u>du</u>
Allocator self-test	<u>ti</u>
Type of the radiator	<u>tot 2</u>
Heat output of the radiator	<u>5000</u>
Coefficient K_{CHF}	<u>1.050</u>

To switch between the submenu items, press the button shortly. If the button is not pressed in 20 seconds, allocator switches back to the main menu and the 1st item will be displayed.

4.5.3. Structure of submenu with month values

The consumption values for the monthly billing periods can be displayed up to 11. months back from the current date. When the submenu item "consumption values for the monthly billing period" du is displayed, press and hold the button until notice A-- appears on the display. After release actual date is displayed as e.g. 10.07 (10 - month, 07 - the last two digits of the year).

Table 5: Structure of submenu with month values, type E-ITN 30.3

m0 – current moth, r0 - last two digits of the year	„m0. r0“
x0 – value for current billing period	„x0“
m1 – last month, r1 - last two digits of the year	„m1. r1“
x1 – value at the end of the last month	„x1“
...	...
m11 - 11. month back, r11 - last two digits of the year	„m11. r11“
x11 – value at the end of the 11 th month back	„x11“

Total number of displayed items is 24.

Except current moth, values correspond with measured values at the end of the month from the beginning of the billing period.

To switch between submenu items, press the button shortly. To end this submenu, do not press the button for 20 seconds, allocator will switch back to the main menu and the 1st item (LCD test) will be displayed. Also the long button press can be used to exit. Press and hold the button till --A-- appears. After release, menu item „value for last billing period“ will appear.

4.5.4. Last year of battery life

Battery lifetime is programmed in the microprocessor memory and the last year of battery lifetime is indicated on LCD by blinking of the special symbol: BAT. After finishing this time the symbol stays displayed permanently. Calculated battery lifetime is 10 years + 1 year reserve.

4.6. SETTING OF PARAMETERS

Základní nastavení parametrů indikátoru dle nastavovacího protokolu k objednávce E-ITN 30.6 se provádí ve výrobním závodě. Pozdější změna některých parametrů zákazníkem je možná pomocí „Programovacího přípravku pro změnu parametrů E-ITN 20.xx, 30.xx připojeného k PC nebo notebooku.

4.6.1. List of the programmable parameters of heat cost allocator E-ITN 30.6

- Type of the radiator (the specific types are described in detail in chapter ???)
- heat output of the radiator (range 20 to 5000 W, resolution 20 W),
- coefficient K_{CHF} (range 0.800 to 1.700 [-], resolution 0.001 [-],
- date of the start in case of mode of waiting for a start date,
- date of the summer heating season beginning (for this date, any day in the year can be selected; the minimum interval between the beginning of summer season and beginning of winter season is 3 months)
- date of the winter heating period beginning,
- date of the yearly/monthly billing period beginning (any month in a year can be selected, day must be in the interval <1; 28>),
- optionally displayed data in the LC display
 - current temperature on the radiator sensor
 - current ambient temperature
 - date of the billing period beginning datum začátku účetního období
 - current date
 - current time
- setting of time difference from the GMT
- postponement (in days) of the 12 min transmitting interval in relation to the beginning and the end of the summer season beginning (0 to 60 days)
- SW version of the allocator:
 - SW version = 2 ... setting of the transmission of radio data without ciphering
 - SW version = 3 ... setting of the transmission of radio data with ciphering in AES-128 standard
- ciphering key

4.7. ERROR MODE

In error mode the notice Error is permanently displayed and allocator does neither measure temperatures, count the increase of consumption nor transmit measured data. Allocator just actualizes real time. Allocator switches from working mode to error mode automatically after registration of serious error (e.g. fault in A/D converter, when the power supply of microprocessor was interrupted and loss of data in RAM memory occurred, etc.).

Allocator backups important data to permanent memory daily. Data in this memory are saved even if the power supply is interrupted. Even in the case of battery failure these data are not lost. Saved data could be read by special tools.

5. OTHER INFORMATIONS

5.1. ELECTRONIC SEAL REACTIVATION

The electronic seal is used for detection if allocator was removed from back plate – more in chapter 2. Device description. If you need to re-fit allocator (e.g. replace old radiator with new radiator), it is necessary to reactivate the seal.

1. Insert new latch into allocator (Illustration 3: Electronic seal assembly). If use the old one, please check its condition, especially electro-conductive rubber.
2. Secure the latch with mechanical seal.
3. Read allocator with IRU 10.00 unit (for more informations see Installation and service manual for infra-red reading unit IRU 10.00). Allocator now displays the menu items.
4. Install allocator to the radiator.

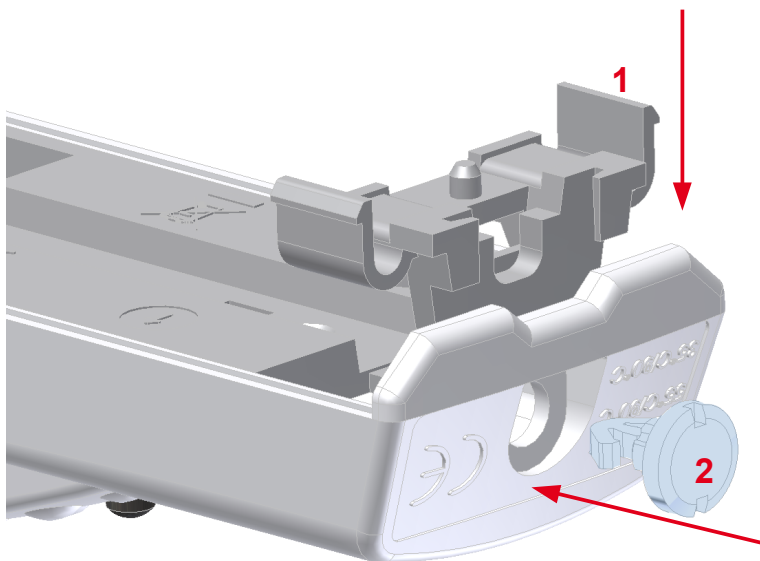

Illustration 3: Electronic seal assembly

5.2. TRANSPORTATION

E-ITN 30 allocators can be transported under following conditions:

- devices can be transported by all usual covered means of transport
- devices must be in original package
- originally packed devices must be stored and secured to avoid mechanical damages during transportation
- devices can not be transported together with aggressive substances
- temperature during transportation from 0 °C to +55 °C
- relative humidity from 45 % to 75 %

5.3. STORAGE

E-ITN 30 is an electrical device and can be stored under these conditions:

- devices must be originally packed by manufacturer and individually stored in antistatic bags
- storage temperature from +10 °C to +30 °C
- relative humidity from 45 % to 75 %
- devices must be stored in clean covered areas without aggressive substances and stored properly to avoid mechanical damage

5.4. APPLICATION AND DISPOSAL



"This device is subject to a waste management in accordance with local legislation."

5.5. DEFECTS AND THEIR ELIMINATION

Any E-ITN 30 defect should be repaired by manufacturer only.

5.6. WARRANTY

If device is installed and handled according to manufacturer instructions mentioned in Installation and service manual, manufacturer provide warranty under the valid legislation unless agreed differently.

The warranty is void if device was used contrary to Installation and service manual or damaged:

- during transport or storage by customer or reseller
- when mounted or dismantled to the customer device
- because of improper handling or installation into other device than agreed in manual
- if the product was exposed to different environment than agreed in manual
- if mechanically or in other way damaged by user

6. ACCOMPANYING DOCUMENTATION

6.1. ORDERING

Order must include Setting protocol that is available on the website for business partners. In every order following items must be specified:

- quantity
- type
- attach Setting protocol – if column "required value" is empty, default values are set
- spare parts (extra pieces)
- delivery date
- method of transport

Order example: 100 pcs E-ITN 30.6, required delivery 28.2.2012, EXW + filled Setting protocol.

6.2. PACKING

	PACKING SHEET
	Production order:
Product: Electronic heat cost allocator E-ITN	

Serial numbers		
Month / year of production	Initial serial number	Final serial number

Package content	
Part	Quantity
Allocator body	
Base plate	
Seal (E-ITN 10.x only)	

Mounting material					
Type	Quantity	Type	Quantity	Type	Quantity
0001		0008		0052	
0002		0009		0053	
0003		0010		0054	
0004		0011		0055	
0005		0012		0056	
0006		0051		0057	

Packed by:	
Date of packing:	Signature:
Controlled by:	
Date of control:	Signature:

In case of material shortage (excess), please mention also responsible employee in complaint protocol.
2012/08a [EN]

APATOR METRA s.r.o., Havlíčkova 919/24, 787 64 Šumperk, Czech Republic, Reg. No. 26834073, VAT Reg. No. CZ26834073
Registered at County court in Ostrava, section C, enclosure 40113
Phone: +420 582 748 444; fax: +420 582 748 440; e-mail: apator@apator.cz; www.apator.cz

Illustration 4: Packing sheet

Allocators are disassembled (allocator, back plates, mounting material) and packed in the boxes of max. 100 pcs. Packing sheet is included in every box (e.g. Illustration 4: Packing sheet) with mark of the producer, device type, number of items and their serial numbers, packing date and the name of the operative who checked and packed the products. The lids of boxes are marked with label "THIS SIDE UP!". The boxes are non-returnable. Boxes are stored always cover up on the standard shipping pallets. Electronic heat cost allocator E-ITN 30.6 is sensitive to static electricity. For this reason, each allocator is shipped in antistatic packaging. Antistatic package should be removed just before installation.

E-ITN 30 INSTALLATION

7. INSTALLATION METHODS

7.1. ALLOCATOR INSTALLATION

The back plate is mounted on the radiator using mounting material in compliance with EN 834 and with Installation and service manual. Mounting material is provided by manufacturer and supplied with allocator.

Installation can be done only by person professionally trained by the manufacturer.

Warning!

Static electricity is harmless for humans but can seriously damage electronic devices. When handling or installing the product follow these rules:

- discharge accumulated static electricity by touching the hand with a grounded metal object (e.g. radiator) before installation,
- keep the product in antistatic package until installation,
- do not touch the PCB before or during installation,
- avoid PCB contact with other items, especially metallic,
- never remove PCB from the housing,
- do not touch metal parts when handle the product (e.g. temperature sensor body).

Use only original parts or parts approved by the manufacturer for installation, pay attention to the tightening of mounting material specified torque.

7.2. ALLOCATOR BACK PLATE

The back plate is made of aluminium alloy and designed to have the best heat transfer from the radiator to the allocator. it is necessary to install back plate to the radiator with recommended mounting material to ensure the optimal thermal contact.

The standard back plate is produced with mounting holes: Illustration 5: Standard back plate. For installation to JAGA Tempo radiators a different back plate is supplied: Illustration 6: Back plate for JAGA Tempo radiators.

If agreed with manufacturer, custom back plate version can be produced, e.g. to install the allocators to formerly installed welding bolts on panel radiators.

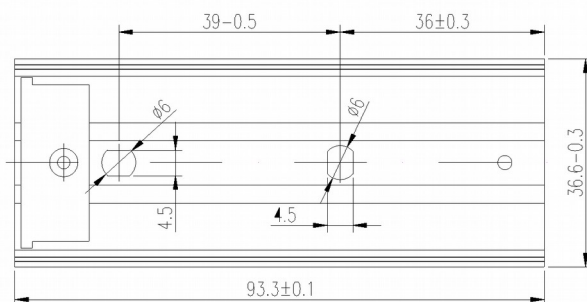

Illustration 5: Standard back plate

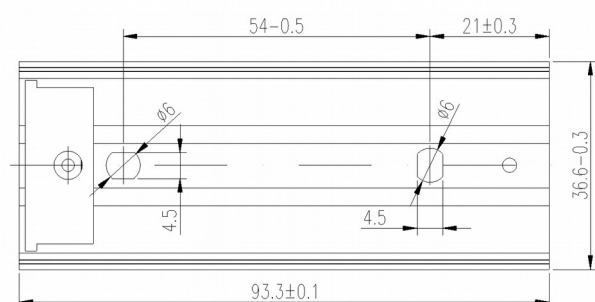

Illustration 6: Back plate for JAGA Tempo radiators

7.3. LIST OF INSTALLATION MATERIAL

Mounting material is used to install allocator to the radiator. Manufacturer does not guarantee the accuracy of coefficient Kc when used a different installation material.

Type	Mounting accessories content
0001	bolt M4x25 + serrated lock washer + clamp III
0002	bolt M4x50 + serrated lock washer + clamp IV + spacer 45
0003	bolt M4x35 + serrated lock washer + clamp III
0004	bolt M4x50 + serrated lock washer + clamp III
0005	bolt M4x115 + serrated lock washer + clamp III
0006	bolt M4x25 + serrated lock washer + clamp
0007	bolt M4x80 + serrated lock washer + clamp III
0008	2 pcs nut M3 special + 2 pcs serrated lock washer + clamp FONAL (8 mm)
0009	2 pcs screw DIN 7982 ST 2.2x16 shape Z
0010	2 pcs nut M3 special + 2 pcs serrated lock washer + clamp FONAL (10 mm)
0011	2 pcs nut M3 special + 2 pcs serrated lock washer + clamp FONAL (12 mm)
0012	2 pcs bolt M3x6 type G AlMg3 + 2 pcs serrated lock washer + 2 pcs nut M3 special
0051	2 pcs bolt M3x6 type G + 2 pcs serrated lock washer + 2 pcs nut M3 special
0052	2 pcs bolt M3x10 type G + 2 pcs serrated lock washer + 2 pcs nut M3 special
0053	2 pcs bolt M3x12 type G + 2 pcs serrated lock washer + 2 pcs nut M3 special
0054	2 pcs bolt M3x10 type G + 2 pcs serrated lock washer + 2 pcs nut M3 special + spacer
0055	bolt M3x6 type G + 2 pcs bolt M4x8 + nut M3 + spacer – tubular heating radiator
0056	bolt M4x25 + serrated lock washer + clamp III
0057	2 pcs bolt M3x8 type G DIN 32 501 ST 36-2 + 2 pcs serrated lock washer + 2 pcs nut M3 spec.

7.4. E-ITN 30 MOUNTING PLACE ON SEGMENTED AND PANEL RADIATORS

Place with suitable relation between the displayed value and the heat emission of the radiator over a sufficiently operating range must be determined for allocator installation. Place of installation must be determined according to the unified criteria in single billing (accounting) unit. E-ITN 30 installation must be permanently protected against manipulation.

Warning: Failure to comply mounting procedure may result allocator malfunction!

7.4.1. Vertical position:

Option 1. - New installation:

Install E-ITN 30 into 75% of the total radiator height (measured from bottom) – in relation to lower hole of back plate. For allocators with centre hole in the back plate (for segmented radiators) is added length of the hole distance 39 mm to 75 % of total height that is related to this centre hole. If the height of the radiator is less than 400mm install allocator to 50 % of total height. Variations of the mounting points height must not exceed ± 10 mm.

Option 2. - Installation instead evaporating allocators RTN 01, RTN 02:

Install E-ITN 30 into 75-80% of the total radiator height (measured from bottom) – in relation to lower hole of back plate. For allocators with centre hole in the back plate (for segmented radiators) is added length of the hole distance 39 mm to 75 % of total height that is related to this centre hole. For radiators with height less than 400mm install allocator to 50 % of total height. Place of installation must be determined according to the unified criteria in single billing unit (e.g. 75 % of radiator height).. Variations of the mounting points height must not exceed ± 10 mm.

7.4.2. Horizontal position:

For both variants of vertical installation, place E-ITN 30 into the half of length L. In cause of odd number of the spaces, place E-ITN 30 into the gap closer to the end of the radiator, i.e. at radiator with 10 segments between 5. and 6. segment. On radiators with length $L > 2000$ mm or radiators with excessive nominal output install two E-ITN 30.

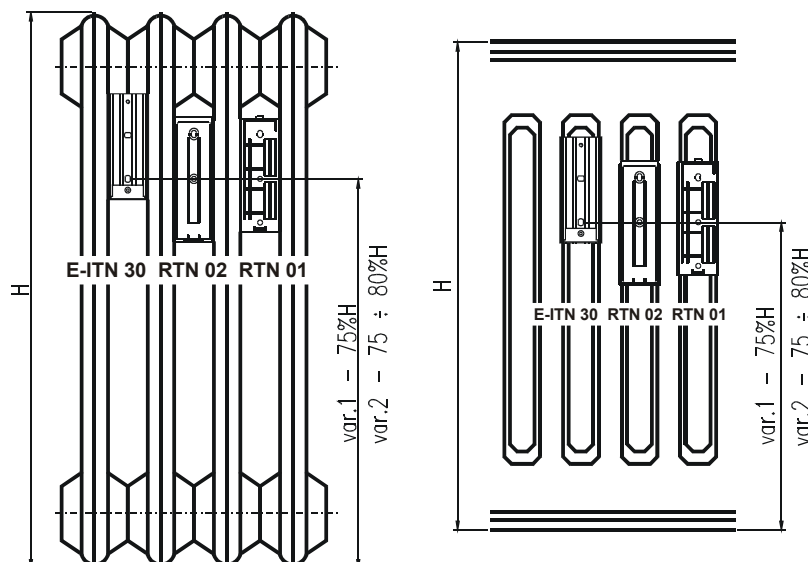

Illustration 7: E-ITN 30, RTN 01, RTN 02 E-ITN 30 location on segmented and panel radiators

7.5. INSTALLATION ON SEGMENTED RADIATORS

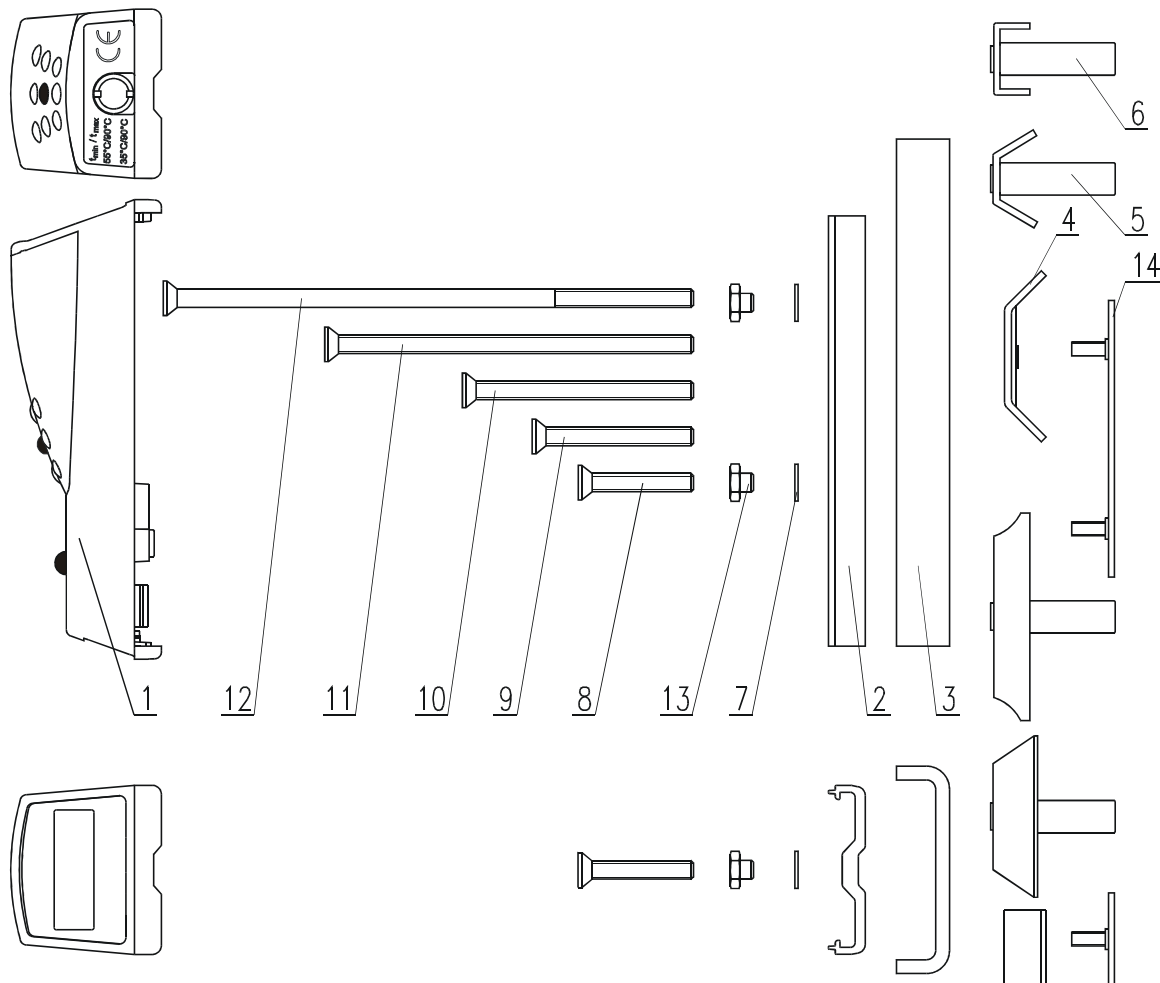

Illustration 8: E-ITN 30 Mounting material for segmented radiators

1	Allocator body	8	Bolt M4x25
2	Back plate	9	Bolt M4x35
3	Spacer 45	10	Bolt M4x50
4	Clamp	11	Bolt M4x80
5	Clamp III	12	Bolt M4x115
6	Clamp IV	13	Nut M3 spec.
7	Washer 4 ČSN 02 1746.25	14	Clamp FONAL

7.5.1. Description of installation

E-ITN 30 back plate should be installed on the radiator with clamps and bolts as follows:

- place back plate into the final location and fix with clamp and bolt through the centre hole,
- tighten to a torque 1 Nm,
- place the allocator into the back plate profile groove from top, align it with the base plate and push allocator to connect it with the back plate.

When using cast iron radiator with a very rough surface (large grain) it is recommended to grind off these grains at the place where back plate will be installed.

After installation, installation protocol has to be filled up (including date of installation, room, type of the radiator, allocator serial number, etc.).

7.5.2. Installation differences

- a) When installing on the radiators with difficult access (KALOR 3, TERMO) follow these steps:
 - insert the mounting bolt through centre hole of the back plate and screw it on several threads to the clamp,
 - slide prepared set from the top between radiator segments (clamp is in upright position) and place in the mounting height,
 - tighten the back plate to a torque 1 Nm.
- b) For installation on radiators with larger distance between the segments (Svratouch radiator):
 - use clamp IV and insert the spacer 45 under E-ITN 30 back plate (Illustration 8: E-ITN 30 Mounting material for segmented radiators).
- c) For radiators with solid and long cells, as KUVAL radiators:
 - use a screw with a length 80 mm (Illustration 8: E-ITN 30 Mounting material for segmented radiators).

7.6. INSTALLATION ON PANEL RADIATORS

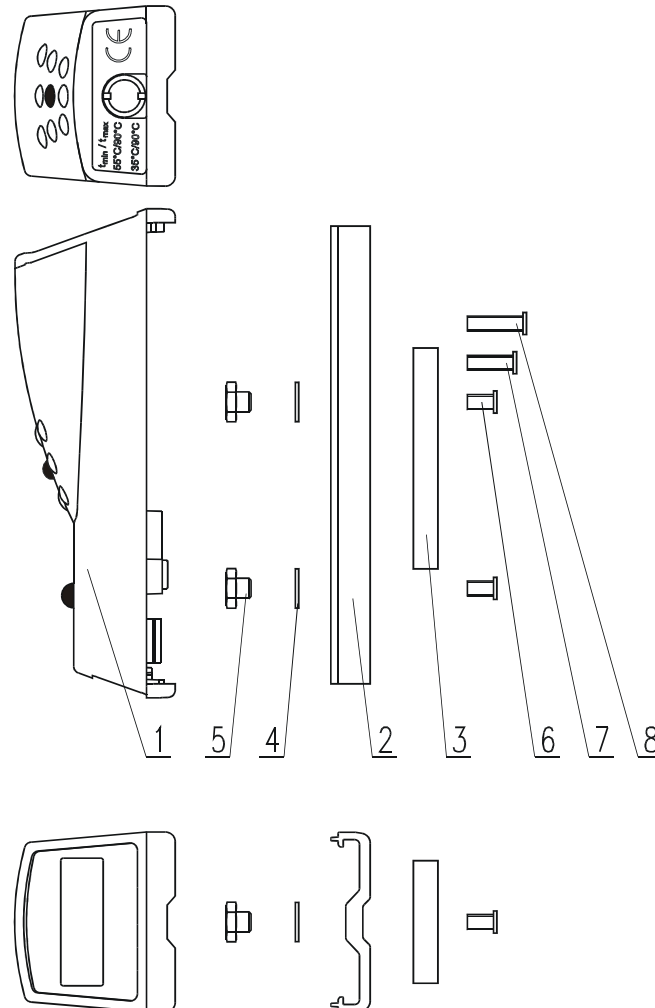

Illustration 9: E-ITN 30 Mounting material for panel radiators

1	Allocator body	5	Nut M3 spec.
2	Back plate	6	Bolt M3x6
3	Spacer	7	Bolt M3x10
4	Washer 4 ČSN 02 1746.25	8	Bolt M3x12

7.6.1. Description of installation

E-ITN 30 back plate should be installed on the panel radiators with two welded bolts thread M3 and special nuts as follows:

- mark the place for both welding bolts on the radiator,
- remove the paint within the diameter of 10 mm on the marked places,
- weld the bolts to the radiator with two-head welding pistol,
- if one-head welding pistol is used, second bolt have to be in distance 39 ± 1 mm towards the upper edge of the radiator, remove the paint within the diameter of 10 mm on the marked place,

- attach back plate to the bolts and than to the radiator, screw the nuts to the bolts with socket wrench M7,
- tighten the nuts to a torque 1 Nm,
- place the allocator into the back plate profile groove from top, align it with the base plate and push allocator to connect it with the back plate.

After installation, installation protocol have to be filled up (including date of installation, room, type of the radiator, allocator serial number, etc.)

Warning!

Televisions or other devices with screen must be apart at least 2-3 meters from the place welding. Devices must be switched off and disconnected from electrical network. Shock during welding can negatively affect pacemaker. It is necessary to warn the user and explain him requirement of his absence during installation.

7.7. INSTALLATION ON HORIZONTAL AND VERTICAL REGISTERS

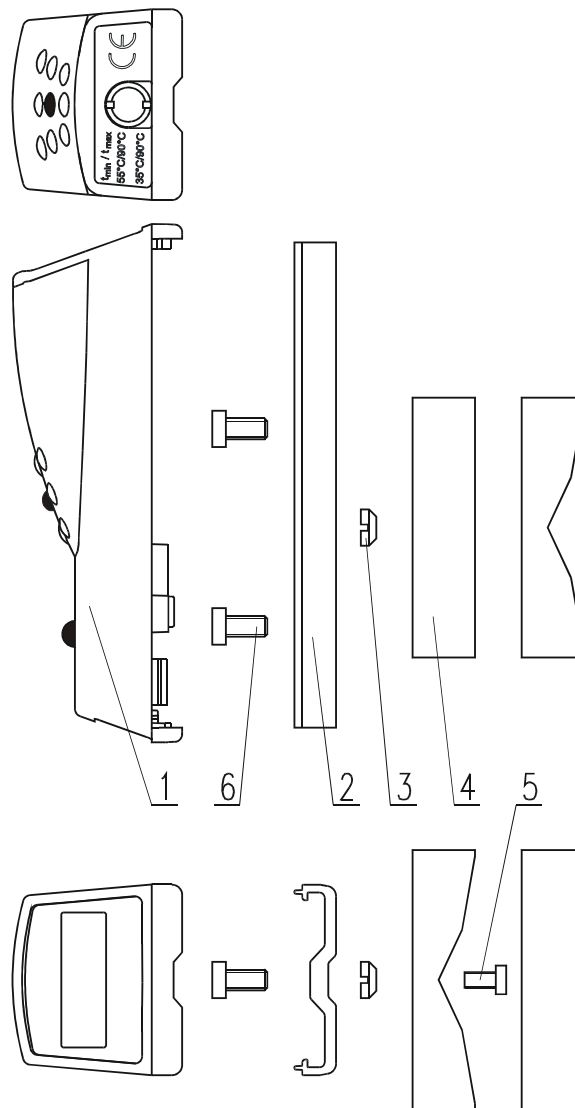

Illustration 10: E-ITN 30 Mounting material for tubular radiators

- | | | | |
|---|----------------|---|--|
| 1 | Allocator body | 4 | Spacer - register for \varnothing 30 to 110 mm |
| 2 | Back plate | 5 | Bolt M3x6 |
| 3 | Nut M3 | 6 | Bolt M4x8 |

7.7.1. Installation description

E-ITN 30 back plate should be installed on the tubular radiators with spacer, welded bolt M3x6 and nut M3, and two bolt M4x8:

- mark the place for welding bolt on the radiator,
- remove the paint within the diameter of 10 mm on the marked place to see metal surface,
- weld bolt M3x6 onto the register pipes with a one-head welding pistol,
- place the spacer on the bolts tighten to a pipe that front surface is always perpendicularly to the ground,
- screw the back plate in vertical position to the spacer with two bolts M4 (pos. 6),
- place the allocator into the back plate profile groove from top, align it with the base plate and push allocator to connect it with the back plate.

7.7.2. Proper E-ITN 30 installation on different register types

Horizontal tubes - bare and ribbed:

- I. Ribbed tube straight with $l \leq 6$ m and bare with $l \leq 12$ m
 - 1x E-ITN 30 in the centre of the tubular element
- II. Ribbed tube straight with $l > 6$ m and bare with $l > 12$ m
 - 2x E-ITN 30 in the beginning and the end of the tubular element
- III. Ribbed or bare tube with one curve
 - 1x E-ITN 30 in the beginning of the tubular element arch
 - in case of register welded into the frame, place E-ITN 30 on a vertical tube
- IV. Ribbed or bare tube with two curves
 - 2x E-ITN 30 in the beginning of the upper curve and in the end of the lower curve
 - in case of register welded into the frame, place E-ITN 30 on a vertical tube
- V. Ribbed or bare tube with more than two curves
 - 2x E-ITN 30 always in the beginning of the upper curve and in the end of the lower curve
 - in case of register welded into the frame, place E-ITN 30 on a vertical tube
- VI. Ribbed or bare tubes connected in parallel
 - 2x E-ITN 30 into the middle or approximately to 75% (odd number of tubes) of the height of the tubular element

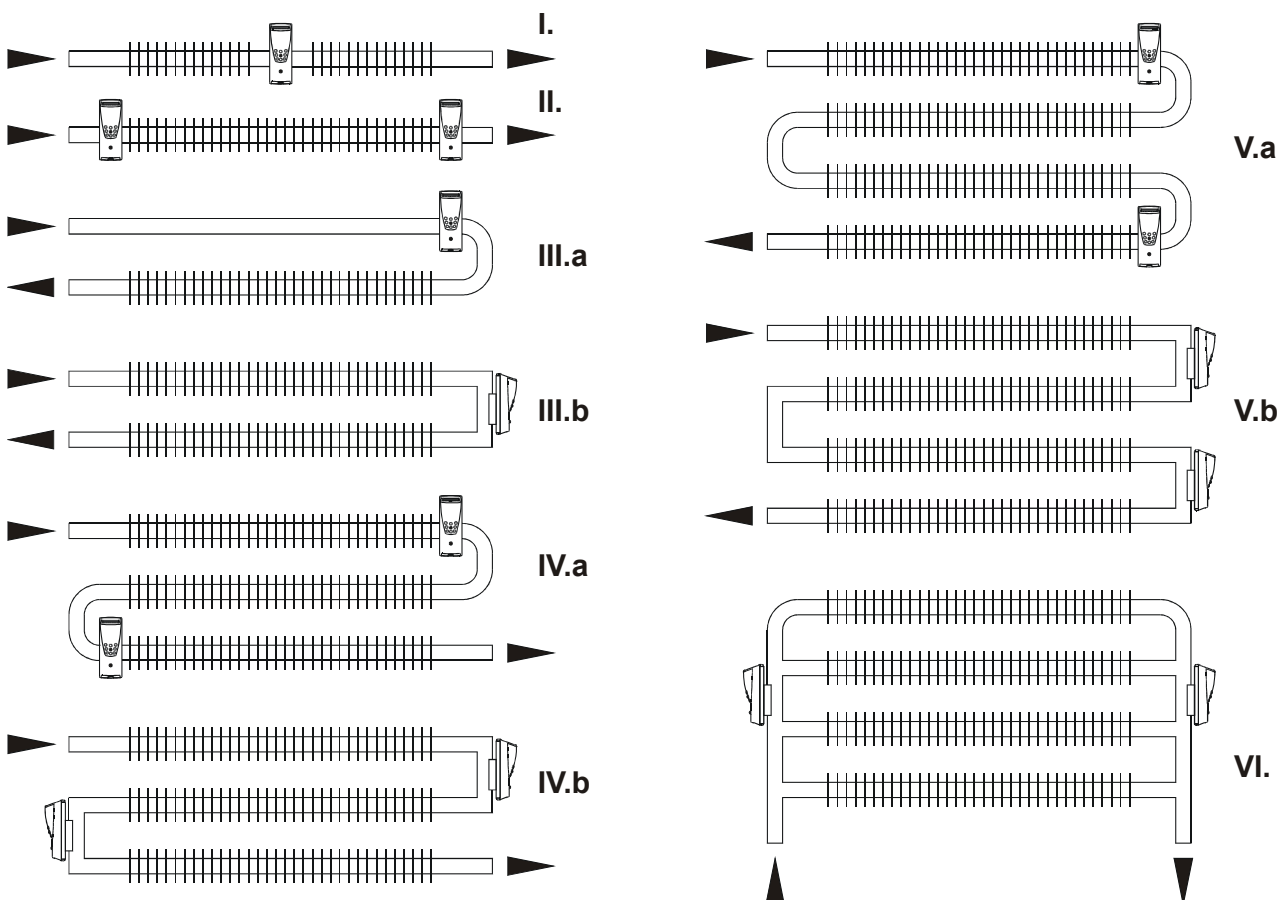

Illustration 11: E-ITN 30 location on horizontal tubular radiators

Vertical bare tubes:

- I. Bare tube with one curve

- 1x E-ITN 30 in the beginning of the tubular element curve
 - in case of register welded into the frame, place E-ITN 30 on a horizontal tube
- II. Bare tube with two curves
- 2x E-ITN 30 in the beginning of the upper curve and in the end of the lower curve
 - in case of register welded into the frame, place E-ITN 30 on a horizontal tube
- III. Bare tube with more than two curves
- 2x E-ITN 30 in the beginning of the first curve and in the end of the (last) upper curve
 - in case of register welded into the frame, place E-ITN 30 on a horizontal tube

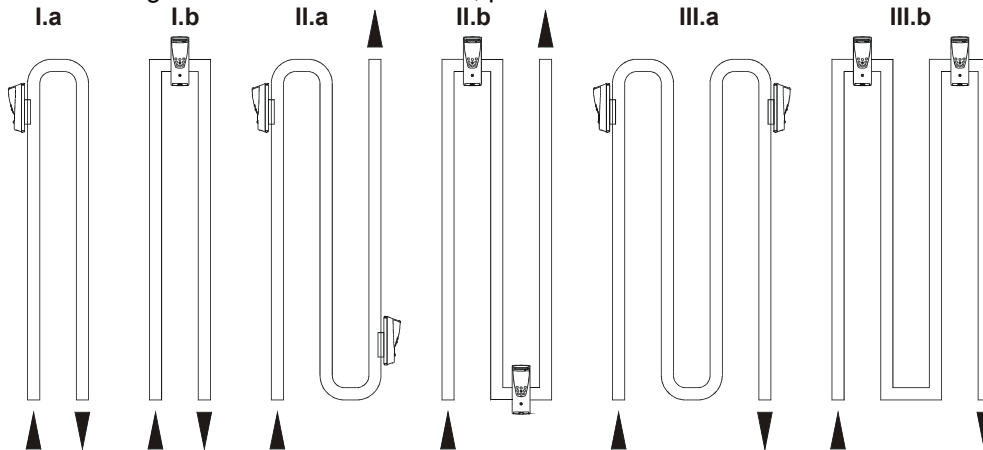

Illustration 12: E-ITN 30 location on vertical tubular radiators

- IV. Two or more small tubes connected in parallel
- 1x E-ITN 30 in 75% of the total height and nearest to the centre of tubular element

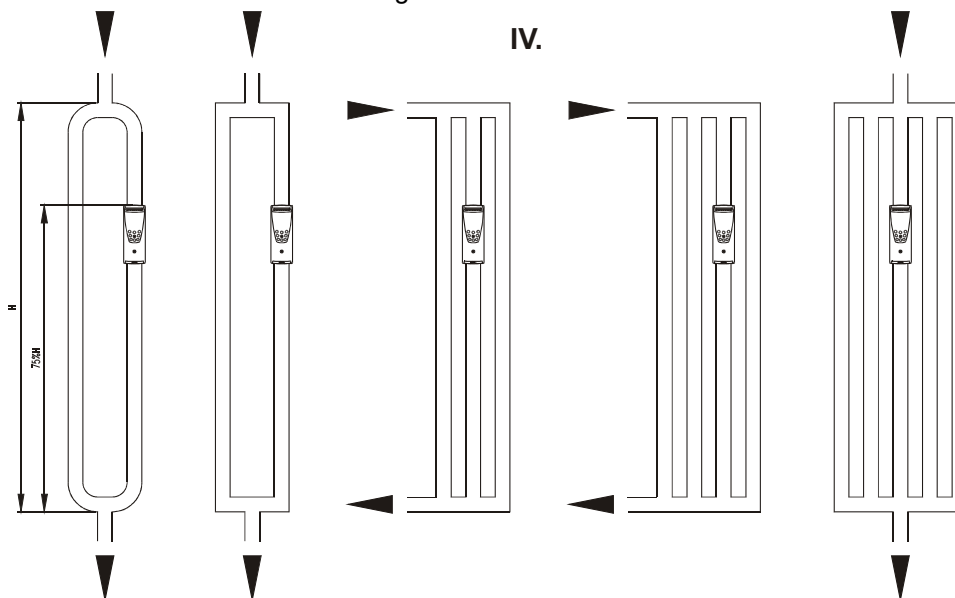
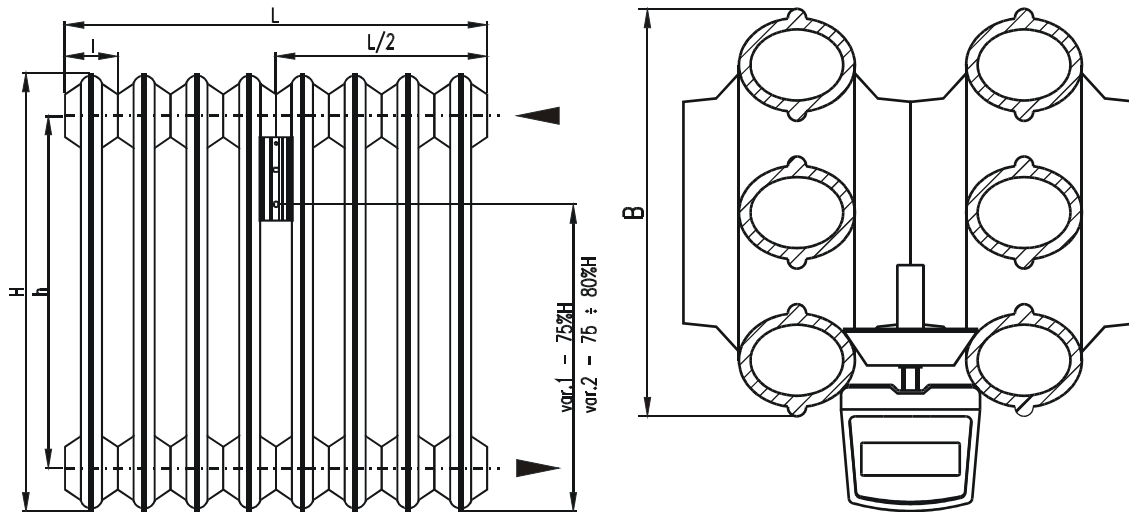

Illustration 13: Illustration 7: E-ITN 30 location on vertical tubular radiators

Note: If register does not match with those patterns, ask manufacturer for information.

7.8. MODEL NO. 1 – CAST IRON RADIATORS

Verified on: KALOR 500/110, manufacturer: ŽDB GROUP a.s., plant Viadrus



Basic dimensions of the KALOR – 500x110 for 10 segments, data for correct allocator installation (mm):

Height – H	Mounting distance - h	Length- L	Segment length - l	Depth - B	MM
580	500	600	60	110	0001

Heat output Q_N [W] of the KALOR radiators can be found in manufacturer catalogue: ŽDB GROUP a.s., plant VIADRUS, Bezručova 300, 735 93 BOHUMÍN

Table 6: Types of heating elements belonging to the model group 1

	Type of the radiator	Manufacturer of the radiator	MM
1	KALOR 1	ŽDB GROUP a.s., plant VIADRUS	0001
2	Slávia 500,1000/100	ŽDB	0004
3	Slávia 500,600,1000/150	ŽDB	0004
4	Slávia 300,500,600,1000/200	ŽDB	0004
5	Slávia 300,500,600,1000/250	ŽDB	0004
6	500/150	KUVAL s.r.o Kralovice	0008
7			
8			
9			
10			

7.9. MODEL No. 2 – CAST IRON RADIATORS WITH FLAT VERTICAL FRONT PANEL

Verified on: KALOR 3, manufacturer: ŽDB GROUP a.s., plant Viadrus

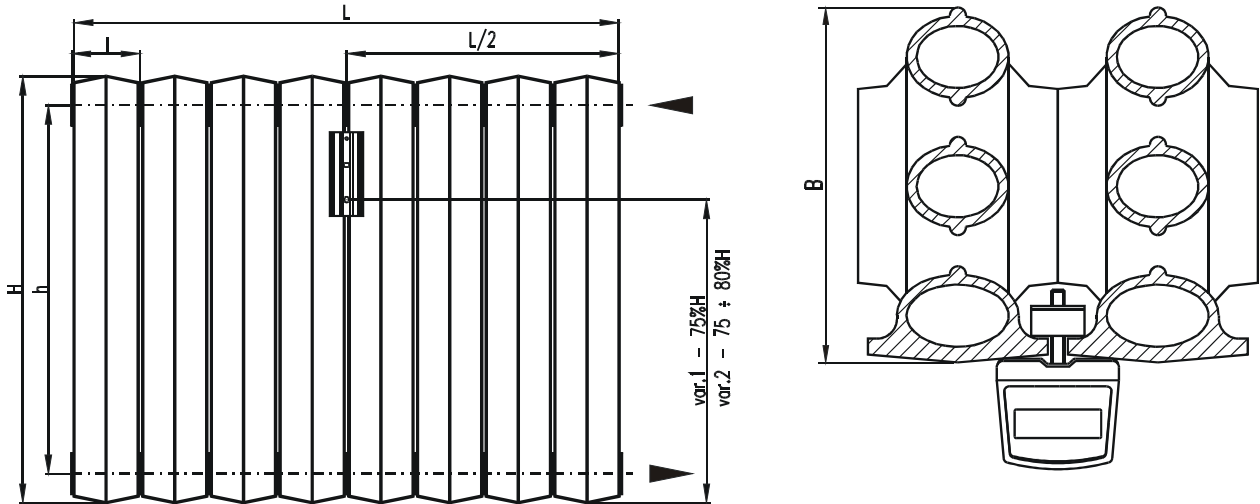

Basic dimensions of the KALOR 3 for 10 segments, data for correct allocator installation (mm):

Length - H	Mounting distance – h	Length- L	Segment length - l	Depth - B	MM
580	500	600	60	110	0006

Heat output Q_N [W] of the KALOR 3 radiator can be found in manufacturer catalogue: ŽDB GROUP a.s., plant VIADRUS, Bezručova 300, 735 93 BOHUMÍN

Table 7: Types of heating elements belonging to the model group 2

	Type of the radiator	Manufacturer of the radiator	MM
1	THERMO	ŽDB a.s., plant VIADRUS	0006
2			
3			
4			
5			
6			
7			
8			
9			
10			

7.10. MODEL No. 3 – CAST IRON RADIATORS WITH DISTANCE PAD

Verified on S-130, manufacturer: Romania

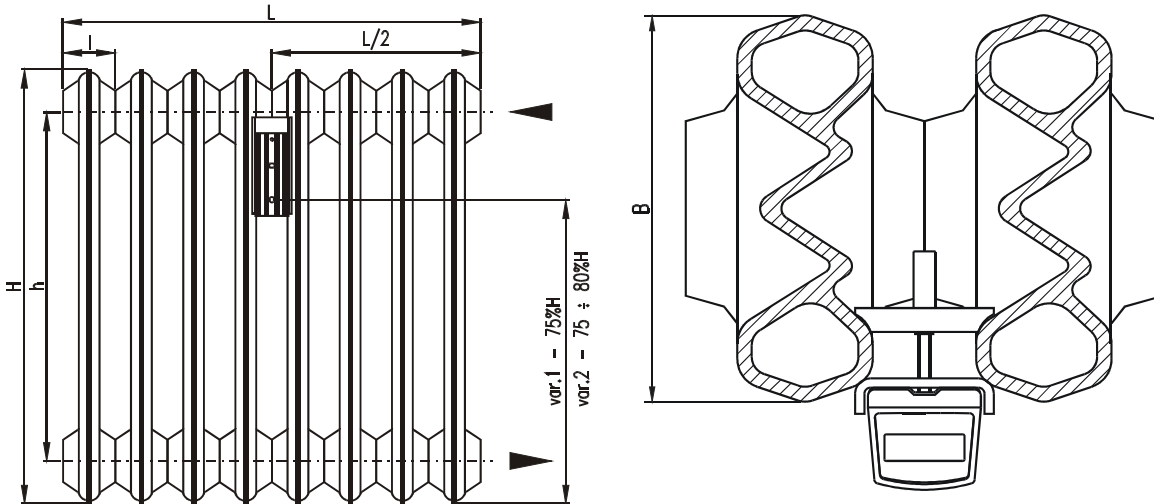

Basic dimensions of the S-130 for 10 segments, data for correct allocator installation (mm):

Height - H	Montanan distance – h	Length - L	Segment length - l	Depth - B	MM
580	500	890	80	130	0002

Table 8: Types of heating elements belonging to the model group 3

	Type of the radiator	Manufacturer of the radiator	MM
1			
2			
3			
4			
5			
6			
7			
8			
9			
10			

7.11. MODEL No. 4 – STEEL RADIATORS

Verified on: NERIA 500/150, manufacturer: NERIA a.s., Hustopeče u Brna

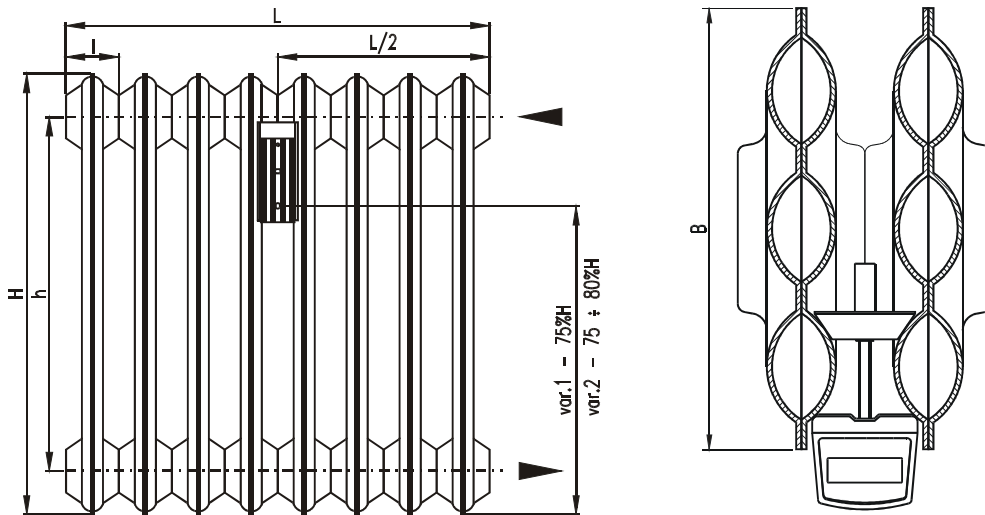

Basic dimensions of the NERIA 500/150 for 10 segments, data for correct allocator installation (mm):

Height – H	Mounting distance - h	Length- L	Segment length - l	Depth - B	MM
607	500	455	45,5	150	0001

Heat output Q_N [W] of the 500/150 radiator can be found in manufacturer catalogue: NERIA a.s., Vinařská 2, 693 01 Hustopeče u Brna

Table 9: Types of heating elements belonging to the model group 4

	Type of the radiator	Manufacturer of the radiator	MM
1	350,500,1000/200;1000/150,200	VD Olomouc	0003
2	500/155	Rukov Rumburk	0006
3	500/178	OPP Rokycany	0006
4	J500/3, 500/200	OPP Beroun se sídlem ve Zdicích	0006
5	500,1000/200	PP Kamenice nad Lipou	0006
6	500/200/1,3	Jihokov Hustopeče u Brna	0006
7	500/150	OPP Gottwaldov	0003
8	500/150, 200, Nora 500/160	OPP Kovotex Prievidza	0006
9	011-500/150	OOP Žilina	0006
10	500/160,220 900/160	ZVL Čalovo	0001
11	MT 520	OSP Martin	0006
12	500/200	OPMP Nové Mesto nad Váhom	0006
13	500/160, 220	Štátný majetok Čadca	0006

7.12. MODEL No. 5 – STEEL RADIATORS WITH DISTANCE PAD

Verified on: Svratouch 500/160, manufacturer: Dílo - Svratouch

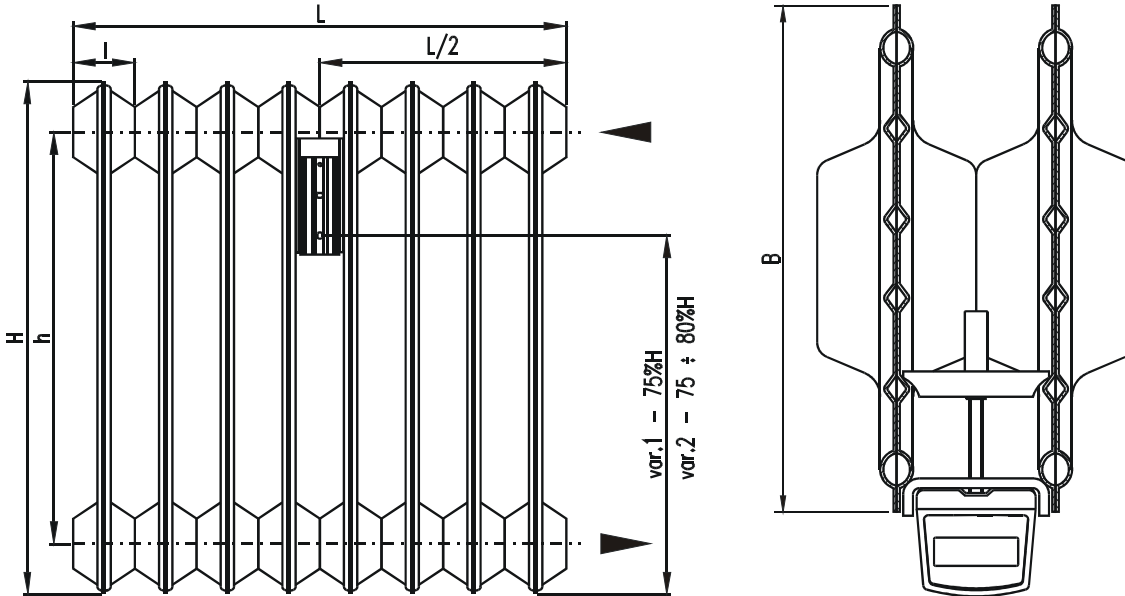

Basic dimensions of the SVRATOUCH 500/160 for 10 segments, data for correct allocator installation (mm):

Height- H	Mounting distance - h	Length- L	Segment length - l	Depth - B	MM
600	500	500	50	160	0002

Heat output Q_N [W] of the 500/160 radiator can be found in manufacturer catalogue: Dílo, výrobní a obchodní družstvo, 539 42 Svratouch

Table 10: Types of heating elements belonging to the model group 5

	Type of the radiator	Manufacturer of the radiator	MM
1	500/185	Dílo - Svratouch	0002
2			
3			
4			
5			
6			
7			
8			
9			
10			

7.13. MODEL No. 6 – PANEL RADIATORS WITH SHAPED FRONT SIDE

Verified on: RADIK, KLASIK mod, type 10, manufacturer: KORADO, a.s. Česká Třebová

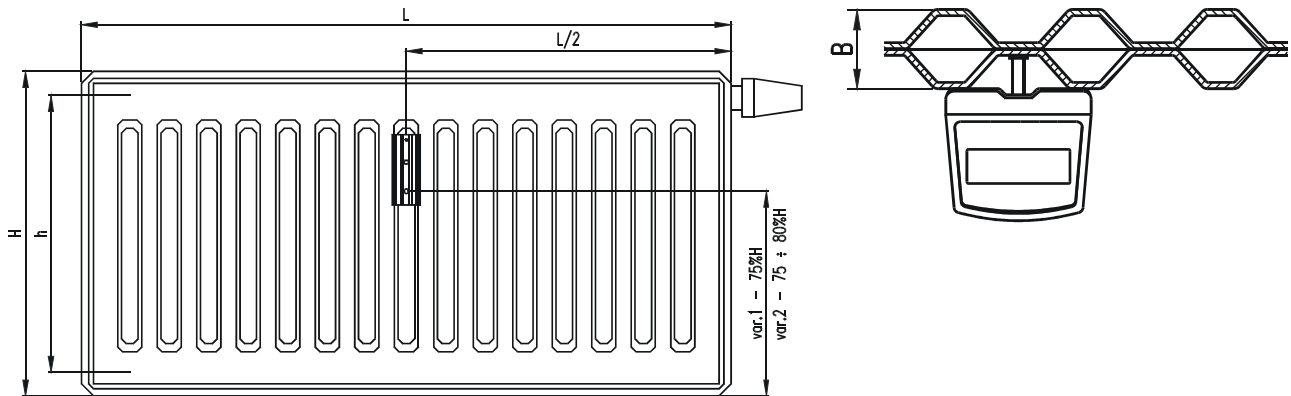

Basic dimensions of the RADIK, KLASIK modification, type 10 and data for correct allocator installation (mm):

Height - H	Mounting distance - h	Length- L	Depth - B	MM
600	546	1200	47	0053

Heat output Q_N [W] of the RADIK radiator can be found in manufacturer catalogue: KORADO, a.s. Bratři Hubálků 869, 560 02 ČESKÁ TŘEBOVÁ

Table 11: Types of heating elements belonging to the model group 6

	Type of the radiator	Manufacturer of the radiator	MM
1	RADIK D91 D93 D95 D97	KORADO a.s., Č.Třebová	0054
2	P-3, P-4, P-4B, PJ-4, PJ-4B, P-40	VSŽ Košice	0053
3	RADIK KLASIK ,VK,VKL,VKU,VKC	KORADO a.s., Č.Třebová	0053
4	Korad	U.S. Stell Košice s.r.o.	0053
5	Profil	Kermi	0054
6	Kompakt, Universalkompakt	Brugman	0054
7	Danuferr LUX - N	Danuferr	0053
8	Dia Plus, Dia Ventil	Rurmo-DiaNorm	0053
9	Purmo VKO	Rettig-Heating Sp.z o.o.	0053
10	VN 4000 NTR	Vogel a Noot	0053
11	Cosmoprofil	Cosmoprofil (Vogel a Noot)	0053
12	Cosmonova	Cosmonova (Vogel a Noot)	0053
13	Compact,Integra,Vertical,Faro	Radson	0053
14	Compact,Novello	Caradon Stelrad B.V.	0053
15			

7.14. MODEL No. 7 – PANEL RADIATORS WITH A FLAT FRONT PANEL

Verified on: RADIK PLAN, VENTIL KOMPAKT mod, type 11, manufacturer : KORADO, a.s. Česká Třebová

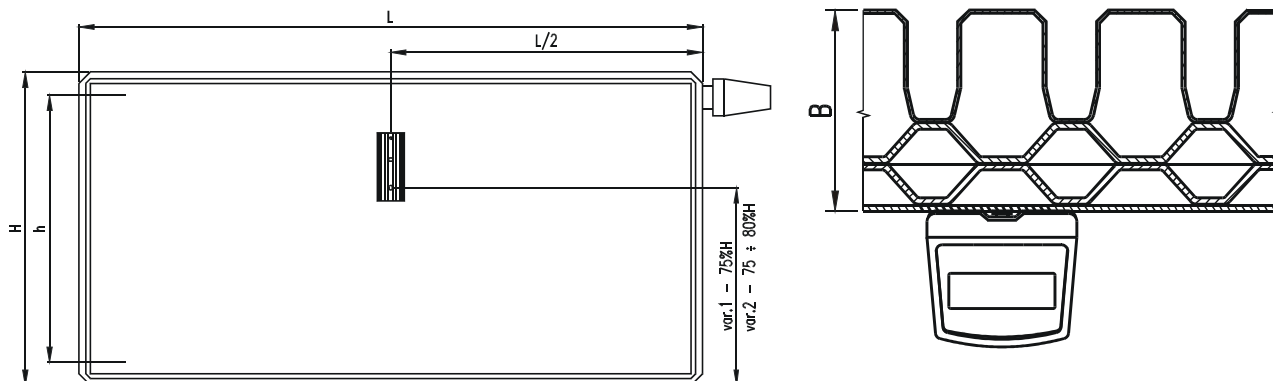

Basic dimensions of the RADIK, VENTIL KOMPAKT modification, type 11 PLAN VK and data for correct allocator installation (mm):

Height - H	Mounting distance - h	Length- L	Depth - B	MM
600	546	1200	65	0052

Heat output Q_N [W] of the RADIK radiator can be found in manufacturer catalogue: KORADO, a.s. Česká Třebová, Bratří Hubálků 869, 560 02 ČESKÁ TŘEBOVÁ

Table 12: Types of heating elements belonging to the model group 7

	Type of the radiator	Manufacturer of the radiator	MM
1	RADIK Plan Klasik, VK, VKL, Hygiene	Korado a.s. Č.Třebová	0052
2	Piano-Universalkompakt	Brugman (JAM Praha)	0052
3	Plan	Kermi	0052
4	Plan-Ventil, Duo Finesse	Purmo - DiaNorm	0052
5	Purmo Plan	Rettig-Heating Sp. z o.o.	0052
6	Radson Planora	Radson	0052
7			
8			
9			
10			

7.15. MODEL No. 8 – TUBULAR RADIATORS - LADDER

Verified on: K 750/1640, manufacturer: Thermal – trend, s.r.o.

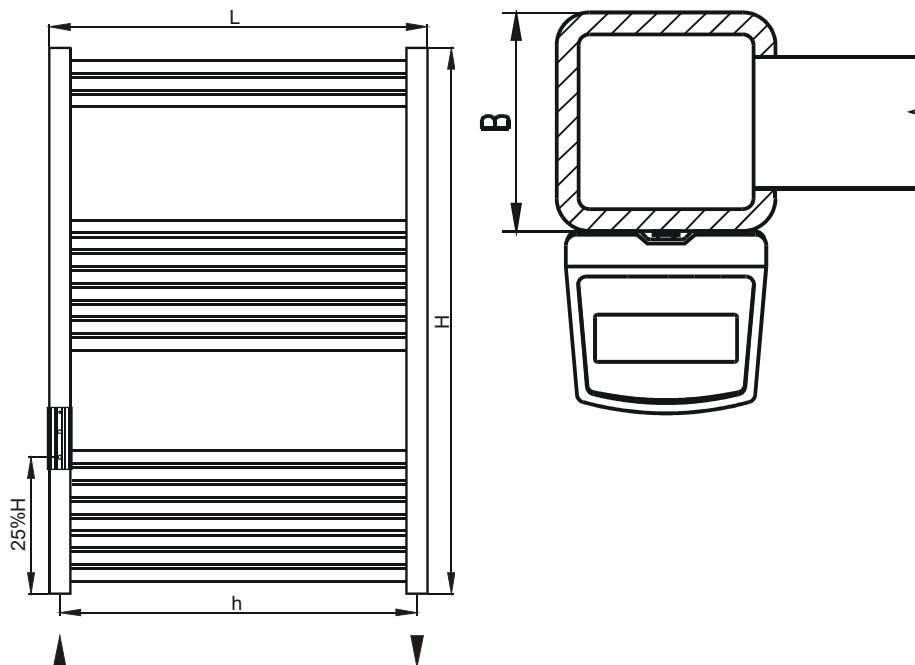

Basic dimensions of the K 750/1640 and data for correct allocator installation (mm):

Height - H	Mounting distance - h	Length - L	Depth - B	MM
1640	720	750	30	0052

Heat output Q_N [W] of the K 600/940 radiator can be found in manufacturer catalogue: Thermal – trend, s.r.o. Starovičky 11, pošta Hustopeče u Brna

Table 13: Types of heating elements belonging to the model group 8

	Type of the radiator	Manufacturer of the radiator	MM
1	KM, KO, K	Thermal – trend, s.r.o.	0052
2	Grenada, Panama	AMTEX Radiátory s.r.o. Blansko	0052
3	Koralux Linear, Linear Classic	KORADO a.s. Č.Třebová	0052
4	Koralux Rondo, Rondo Classic	KORADO a.s. Č.Třebová	0053
5	Clasic, Premier, Eliptic	Neria a.s. Hustopeče u Brna	0053
6			
7			
8			
9			
10			

7.16. MODEL No. 9 – TUBULAR RADIATORS – LADDER WITH OVAL BASE

Verified on: KDO 750/1640, manufacturer: Thermal – trend, s.r.o.

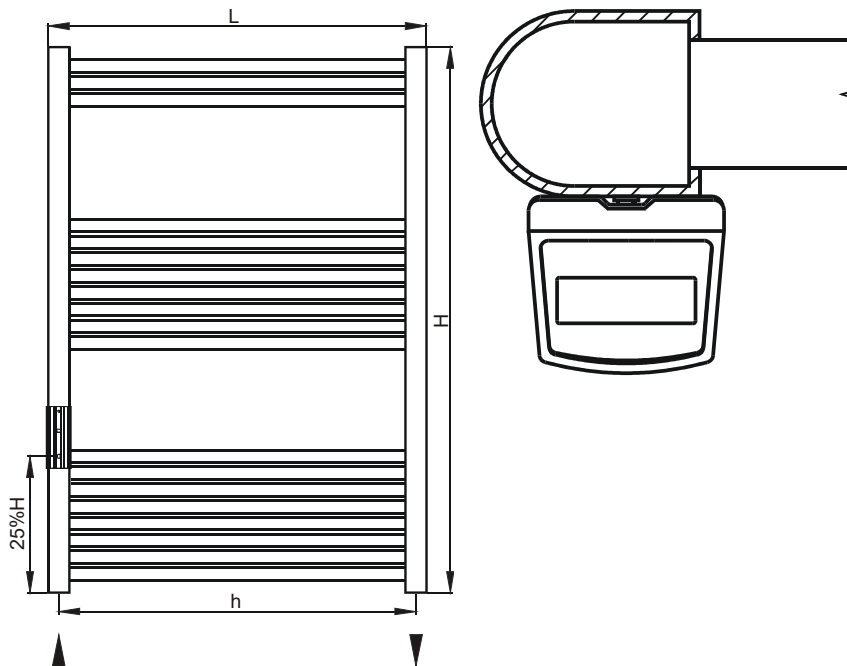

Basic dimensions of the K 750/1640 radiator and data for correct allocator installation (mm):

Height-H	Mounting distance - h	Lenght-L	MM
1680	708	750	0052

Heat output Q_N [W] of the K 600/940 radiator can be found in manufacturer catalogue: Thermal – trend, s.r.o. Starovičky 11, Hustopeče u Brna

Table 14: Types of heating elements belonging to the model group 9

	Type of the radiator	Manufacturer of the radiator	MM
1	KDO	Thermal – trend, s.r.o.	0052
2			
3			
4			
5			
6			
7			
8			
9			
10			

7.17. MODEL No. 10 – RADIATORS MADE FROM SMOOTH OR RIBBED TUBES - REGISTER

Verified on: smooth register 2x1200 - \varnothing 76/3, manufacturer: unknown

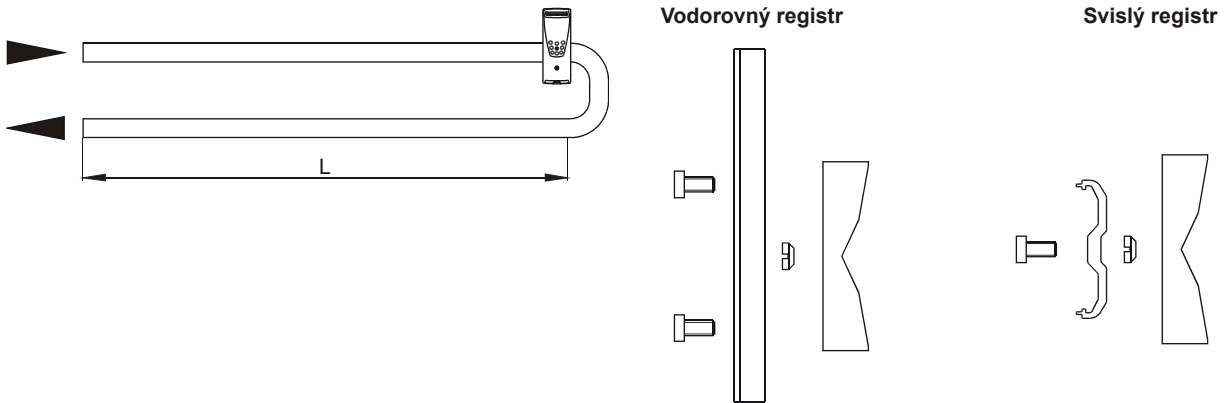

Steel registers are used only in areas with low hygiene and esthetic requirements. Dimensions are chosen accordingly to needs. Registers are usually made accordingly to drawings attached with project. Mounting material can be used for pipes from \varnothing 30 to \varnothing 110 mm.

Basic dimensions of the horizontal radiator register \varnothing 76 (mm):

Total length - L	Tube diameter– \varnothing d	Mounting location	MM
2x1200	76	As per diagram	0056

Illustrations and the figures are indicative only. Installation of two allocators must be recorded in installation protocol.

For more information's about E-ITN 30 installation refer to chapter: 7.7. Installation on horizontal and vertical registers.

7.18. PATER No. 11 – ALUMINIUM RADIATOR WITH VERTICAL RIBS

Verified on: FONAL TYP A 650-175, manufacturer: Kovohutě Mníšek

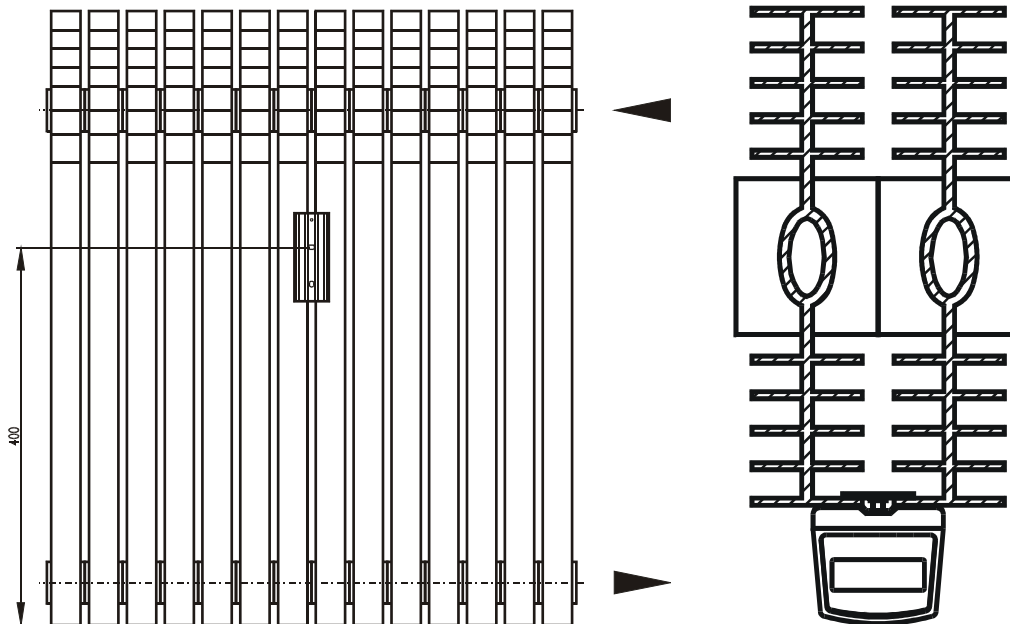

Basic dimensions of the FONAL A 650-175 and data for correct allocator installation (mm):

Height	Mounting distance	MM
650	500	0009

Heat output Q_N [W] of the radiator can be found in manufacturer catalogue: Fonal Kovohutě Mníšek, Mníšek pod Brdy

Table 15: Types of heating elements belonging to the model group 11

	Type of the radiator	Manufacturer of the radiator	MM
1			
2			
3			
4			
5			
6			
7			
8			
9			
10			

7.19. MODEL No. 12 – ALUMINIUM RADIATOR WITH VERTICAL RIBS

Verified on: SOLAR 500/10, manufacturer: LIPOVICA trade s.r.o. , Reissigova 15, BRNO 612 00

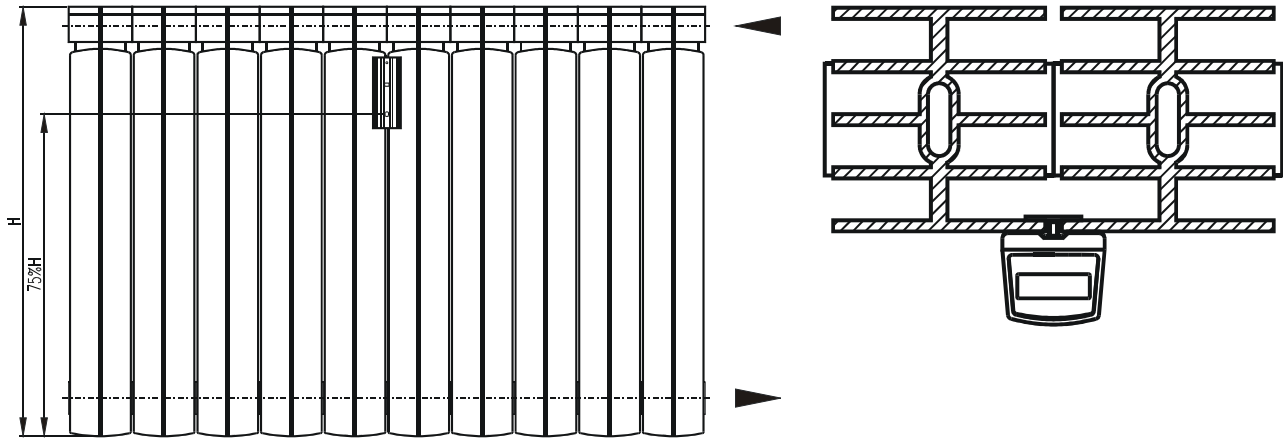

Basic dimensions of the SOLAR 500 radiator and data for correct allocator installation (mm):

Height - H	Mounting distance - h	Length	MM
579	500	820	0009

Heat output Q_N [W] of the radiator find in manufacturers catalogue:

LIPOVICA trade s.r.o. , Reissigova 15, BRNO 612 00

Table 16: Types of heating elements belonging to the model group 12

	Type of the radiator	Manufacturer of the radiator	MM
1	SOLAR, EKONOMIK	LIPOVICA trade s.r.o.	0009
2	EKO CALIDOR	TRIO Brno s.r.o.	0009
3	FONDITAL		0009
4	GHIDINI	WÄRME s.r.o. Brno	0009
5	TEPOR	Kamenice u Prahy	0009
6	CM	REGULUS s.r.o.	0009
7	ODEON	F.A.I.S. Brno k.s.	0009
8	GIACOSTAR	GIACOMINI	0009
9	ARMAT	ARMATMETAL s.r.o.	0009
10	Plano	Lipovica	0008

7.20. MODEL No. 13 – RADIATOR JAGA TEMPO

Verified on: TEMF.040/110/10, manufacturer: JAGA N. V. , Čsl. armády 325, 253 01 Hostivice

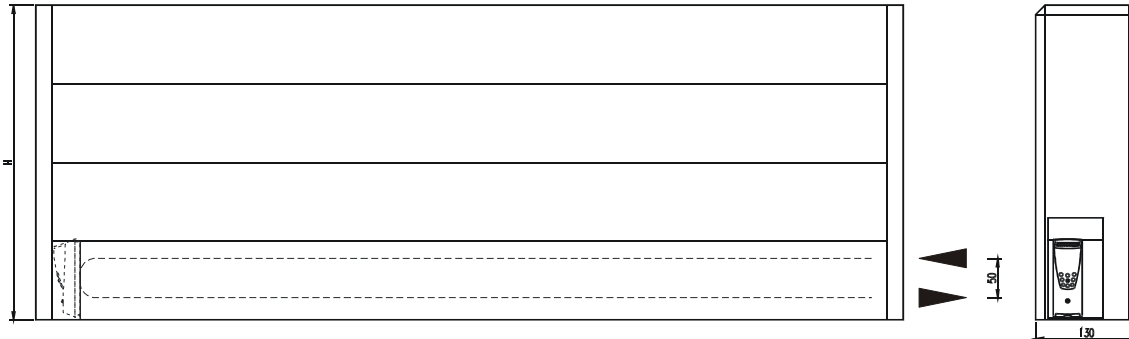

Basic dimensions of the TEMF.040/110/10 radiator and data for correct allocator installation (mm):

Height - H	Mounting distance - h	Length	MM
400	50	1100	0010

Heat output Q_N [W] of the radiator can be found in manufacturer catalogue: JAGA N. V. , Čsl. armády 325, 253 01 Hostivice

Table 17: Types of heating elements belonging to the model group 13

	Type of the radiator	Manufacturer of the radiator	MM
1	Type 10 a type 11	JAGA N.V.	0010
2			
3			
4			
5			
6			
7			
8			
9			
10			

Warning!

Allocators E-ITN 30 designed for installation to JAGA Tempo radiators include a back plates with a different distance of the mounting holes (Illustration 6: Back plate for JAGA Tempo radiators). Please pay attention to use right back plate.

Copper mounting plate used for allocator installation is provided by radiator manufacturer as a part of the radiator. Installation material supplied by the manufacturer serves only to fit back plate to mounting plate.

7.21. MODEL No. 14 – RADIATORS KORATHERM HORIZONTAL K22HM

Verified on: Koratherm horizontal K22HM, manufacturer: KORADO a.s., Bří Hubálků 869, 560 02 Česká Třebová

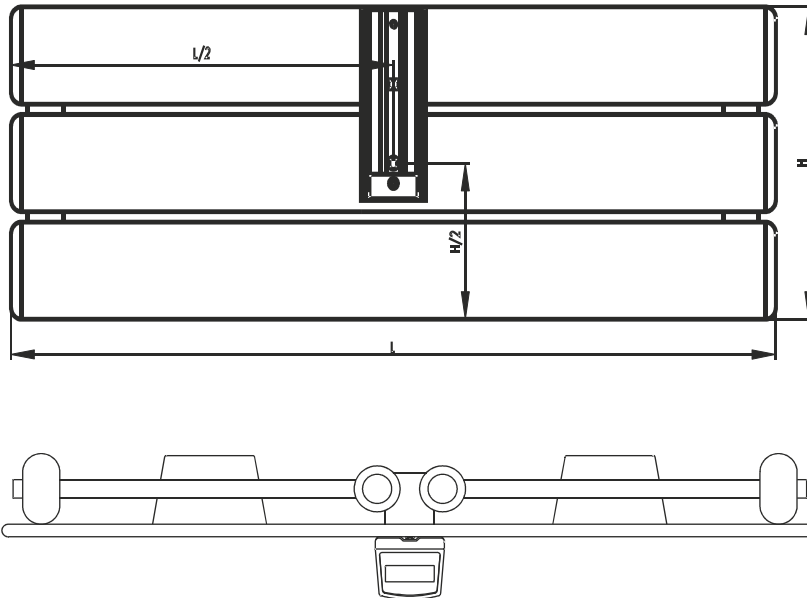

Basic dimensions of the Koratherm horizontal K22HM radiator and data for correct allocator installation (mm):

Height - H	Mounting distance - h	Length	MM
218	50	500	0052

Heat output Q_N [W] of the radiator can be found in manufacturer catalogue: KORADO a.s., Bří Hubálků 869, 560 02 Česká Třebová

Tabulka 18: Types of heating elements belonging to the model group 14

	Type of the radiator	Manufacturer of the radiator	MM
1	KORATHERM horizontal K22HM	KORADO a.s.	0052
2			
3			
4			
5			
6			
7			
8			
9			
10			

7.22. MODEL No. 15 – RADIATORS OT KORAL

Verified on: OT KORAL , manufacturer: Kovohutě Mníšek, a.s., Mníšek pod Brdy 252 10.

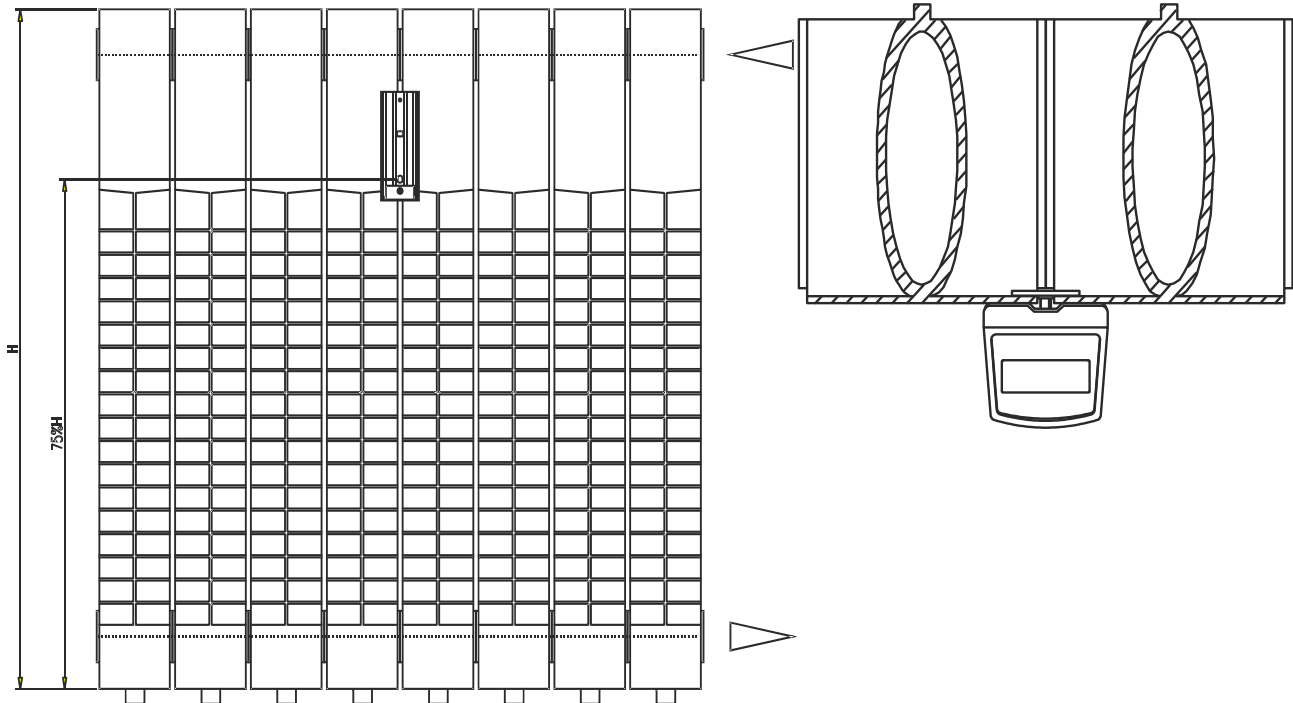

Basic dimensions of the Koral radiator and data for correct allocator installation (mm):

Height - H	Mounting distance - h	Length	Depth	MM
600	450	660	80	0009

The heat output Q_N [W] of the radiator can be found in manufacturer catalogue: Kovohutě Mníšek, a.s., Mníšek pod Brdy 252 10

Tabulka 19: Types of heating elements belonging to the model group 15

	Type of the radiator	Manufacturer of the radiator	MM
1	OT KORAL	Kovohutě Mníšek, a.s.	0009
2			
3			
4			

7.23. MODEL No. 16 – KORATHERM VERTIKAL K20 V

Verified on: OT Koratherm , výrobce: KORADO,a.s., Bří Hubálků 869, Česká Třebová.

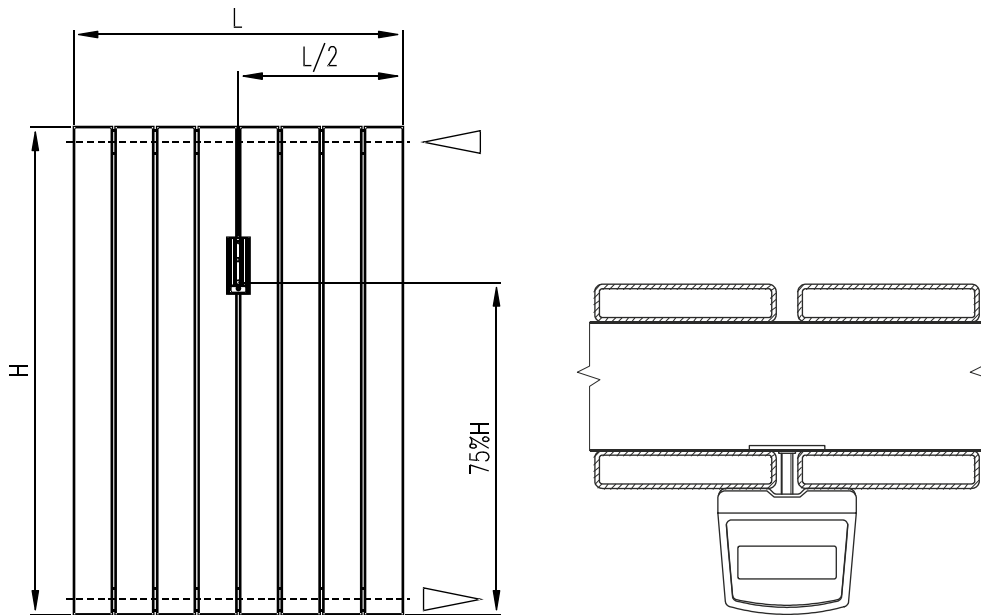

Basic dimensions of the Koratherm radiator and data for correct allocator installation (mm):

Height - H	Depth - B	Length	MM
1800	74	588	0020

The heat output Q_N [W] of the radiator can be found in manufacturer catalogue: KORADO,a.s., Bří Hubálků 869, Česká Třebová.

Tabulka 20: Types of heating elements belonging to the model group 16.

	Type of the radiator	Manufacturer of the radiator	MM
1	Koratherm Vertikal K20 V	KORADO, a.s.	0020
2			
3			
4			