

CAPILLARY THERMOMETER TCS 48

DESCRIPTION

TCS 48 is pressure thermometer intended for temperature measurement in applications where measuring place is different from place of reading. Thermometer consists of a capillary system and head. The thermometer head is constituted of casing and plastic window that protects marker, dial with scale and elastic measuring component.

Thermometer consists of tube in shape of Archimedes' spiral. The inner pressure, that is induced by dialation of the liquid held in the sensor, causes the spiral to uncoil. This rotation movement, that is proportional to the pressure, is transferred to the pointer indicating a measured value at the scale. The sensor and the spiral are connected with a capillary.



USE

Capillary thermometers can be universally used for temperature measurement in their measuring range (20 - 100°C). Measured temperature must not exceed the upper limit of measuring range. Thermometers can be used in any position. Thermometer head can be installed in environment with maximal temperature 40°C. Temperature sensor must be placed in liquid or gaseous medium that does not damage copper and its alloys. In other cases, the sensor must be placed in thermometer well.

INSTALLATION AND MAINTENANCE

Thermometer installation is done by inserting the thermometer head into the hole with dimensions as mentioned in drawing and by inserting the temperature sensor in a thermometer well. The thermometer head can be placed in any position. To prevent capillary vibration it is necessary to fix it at two or more points approximately equally spaced along the capillary. Bending radius of capillary must be 5 mm or bigger. The thermometer does not require any maintenance.

TECHNICAL DATA

Scale range	0 to 120°C
Measuring range	20 to 100°C
Scale division	2K
Accuracy	±4% from scale range
Sensor dimensions	∅ 6x35,5 mm
Time constant	15 s
Capillary length	1450 mm
Minimal bending radius of capillary	$R_{min} = 5\text{mm}$

TECHNICAL DRAWINGS

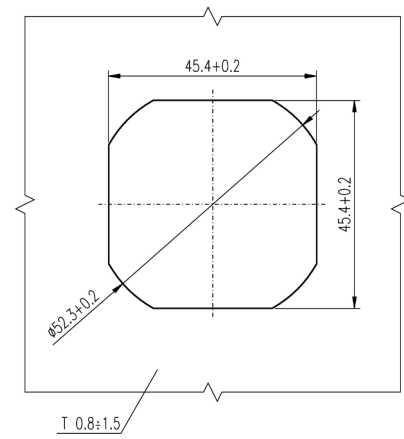
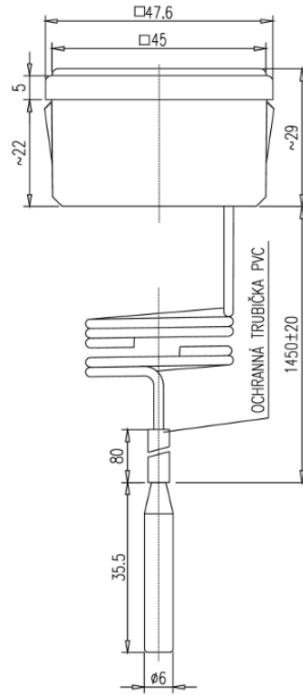

CONTACTS

APATOR METRA s.r.o.

Havlíčková 919/24

787 01 Šumperk

Czech Republic

Tel.: +420 583 718 261

E-mail: prodej@metra-su.cz

Web: www.metra-su.cz

Your distributor:

The manufacturer reserves the right to change design, technical specifications and accessories without prior notice.

K2024/3a