

Electronic radio modules for residential water meters Apator Powogaz

OP-04-1A (NAXOM-1A)

DESCRIPTION

The OP-04-1a radio frequency module is intended for reading and wireless output transmission of the metering data from Apator Powogaz S.A. water meters over the Wireless M-Bus communication protocol. The module is compatible with OMS equipment. This module also features a uniquely extensive local and remote configuration of the operating parameters. The communication module scans the indicator of the connected water meter's counter by detecting the direction of the indicator revolutions. This detection enables remote transmission of the actual indications of the water meter counter. The specified battery life is 12 years maximum, with the standard transmission configuration for a predefined data transmission schedule and environmental conditions (class T50)

Module OP-04-1a is equipped with ½ AA battery.

APPLICATION

The OP-04-1a communication module is intended only for installation on the JS/JS90 1.6÷2.5 Smart+; JS 1.6÷2.5 Smart C+; JS/JS90 1.6÷2.5 Smart D+, manufactured by Apator Powogaz S.A.

Module type	Water meter type		
OP-04-1a (NAXOM-1a)	JS 1,6-02 Smart+	JS 1,6-02 Smart C+	JS 1,6-05 Smart D+
	JS 1,6-03 Smart+	JS 1,6-03 Smart C+	JS 2,5-05 Smart D+
	JS 2,5-02 Smart+	JS 2,5-02 Smart C+	JS 2,5-G1-05 Smart D+
	JS 2,5-03 Smart+	JS 2,5-03 Smart C+	JS90 1,6-05 Smart D+
	JS 2,5-G1-02 Smart+	JS 2,5-G1-02 Smart C+	JS90 2,5-05 Smart D+
	JS90 1,6-02 Smart+		JS90 2,5-G1-05 Smart D+
	JS90 1,6-0,3 Smart+		JS 1,6-07 Smart D+
	JS90 2,5-02 Smart+		JS 2,5-07 Smart D+
	JS90 2,5-03 Smart+		JS 2,5-G1-07 Smart D+
	JS90 2,5-G1-02 Smart+		JS90 1,6-07 Smart D+
			JS90 2,5-07 Smart D+
			JS90 2,5-G1-07 Smart D+

FEATURES

- Compatible with wide range of single-jet water meters and select volumetric water meters form Apator powogaz S.A.
- Easy and tamper-free installation on the water meter, even if it has already been deployed for operation
- Quick configuration with mobile equipment
- Real time clock with winter/summer time and leap years features
- Water meter type selection and configurable water meter-related properties
- Five operating modes to enable adjustment of the data transmission interval to the user's individual requirements
- Detection, logging and indication of water usage measurement abnormalities and module performance abnormalities by indicator of all events
- Storing and reading the measured volume data from 1 to 16 months
- Supports custom configuration of the data transmission interval
- Water consumption readout with mobile terminals in the readout collector system or using a telemetry network in a stationary system
- Measurement data readouts form water meters are fully immune to all interference from external magnetic fields
- Wireless data transmission driven by the Wireless M-Bus communication protocol
- Compatible with AMR and data transmission structure equipment in compliance with Open Metering System Vol. 3 or Vol. 4
- Data transmission encryption with 128-bit AES-CBC mode 5 or OMS3 or mode 5 or 7 for OMS 4
- Operates on the 868 MHz unlicensed ISM band

DATA READING AND WRITING

It enables reading and writing the following data over RF communication:

- Water meter number
- Current date
- Operating days
- Operation/transmission times
- Transmission frame contents configuration
- Day of recording the monthly volume
- Current volume
- Volume history
- Current flow rate
- Event details and threshold values
- Event auto-delete configuration

Event information and historical volume values can be deleted; the communication module can be switched over to storage mode (all possible events are defined at the events point).

TRANSMISSION ENCRYPTION (AES KEY)

To ensure confidentiality of the metering data, the RF-transmitted consumption data is protected with the AES-128 + CBC encryption algorithm (which guarantees variance of the transmitted data when there are no changes in the measured volume). The received data can be decrypted of the encryption key is known. The key is 32 alphanumeric characters. The encryption key is also required for reading and writing of the configuration data. A new encryption key can be set up if the current key of the communication module is known.

VOLUME HISTORY

The communication module collects and saves historical volume data for the last 16 months. The volume written day can be configured (day 1 to 28, or the last day of the month). The data frame contains the historical data from 1 to 16 months back. The service mode allows accessing the whole historical content (irrespective of the months configured to be transmitted in an RF frame).

EVENTS

The communication module can detect, log and show water usage measurement abnormalities, and module performance abnormalities by the indication of events. In the communication module's configuration, the custom events are selected where the details should be output on a spontaneous data frame whenever such an event occurs. The events are appended periodically to the data frames. Each next data frame holds the details of the successive, logged event.

The following events have been defined:

Custom events that are relevant to the customer and concern the flow, battery status or operating conditions:

- Magnetic field: an external magnetic field was detected
- Disconnected: the communication module has been separated from its water meter
- Zero Flow thresholds: maximum daily volume, maximum total volume over a preset number of days, number of days, a zero flow condition is detected when the total volume over a preset number of days is below the threshold, or when the maximum daily volume is not exceeded on any of the preset days
- Minimum flow rate (thresholds: flow rate, minimum volume): this event is detected when the device records the minimum volume (or higher volume) at a flow that is below the threshold
- Maximum flow rate (thresholds: flow rate, successive instances of flow over the threshold): this event is detected when a flow above the threshold is recorded over the successive 10-second periods, and the number of those instances is at least the one defined for the threshold
- Reverse flow (threshold: reverse flow volume): this is a reverse flow with a volume that exceeds the threshold
- Water leak (thresholds: water meter start flow, leak time (multiple of 10 minutes)): this event occurs when a continuous flow is detected with a value above the threshold for a preset duration
- Battery operating time exceeded (threshold: min. Count of operating days): this event occurs when the number of the communication module operating days exceeds the threshold
- Access error (threshold: number of failed attempts to communicate with the module): this event occurs when the number of failed communication attempts exceeds the defined threshold

Service events that are relevant to the manufacturer. The event emergence and specifics are available to the manufacturer only and not displayed in meter readout apps.

TECHNICAL DATA

Module	OP-04-1a NAXOM-1a
Cooperation with water meters	Only with water meters: JS/JS90 1,6÷2,5 Smart +; JS 1,6÷2,5 Smart C+; JS/JS90 1,6÷2,5 D+
Model	15.65.1.1.20
Communication standard	OMS gen. 3 en. mode 5 or no security, and IMS gen. 4 en. mode 5 or 7
Power supply	3 V battery, size 1/2 AA
Operating temperature	0°C to 55°C
Signal output	Internal antenna
Transmission frequency	868 MHz
Communication protocol	Wireless M-Bus
Consumption detection	Optical
Power output	10 mW / 50 Ω
Power output level stability	+1 dB / -3 dB
Sensitivity	-108 dBm
Operating time	12 years max.*
Outdoor range	350 m
Ingress protection	IP 65
Installation method	Directly on water meter
Weight	36 g

***Configuration-dependent:**

Configuration example: spontaneous data frame standard transmission interval: 60 seconds for 10 hours a day, 5 days a week; 768 seconds at all other hours; transmission data frame contents; clock time, volume, event flags, water meter number, last 12 months of history, event details. The battery operating may vary with the actual configuration settings. Contact the manufacturer for detailed information about the specific configuration.

Temperature-dependent:

Module operation in the following temperature ranges: 80% of operating time at 30°C maximum; 10% of operating time at 30-40°C; 10% of operating time at 55°C maximum. The applied temperature profile matches the average temperature profile for the housing sector.

DIMENSIONS

Parameter	Unit	OP-04-1a
h	mm	16,5
H	mm	86,6
H ₂	mm	67,6
H ₃	mm	26,4
L	mm	110 (G3/4"); 130 (G1")

OP-04-1a (½ AA battery)

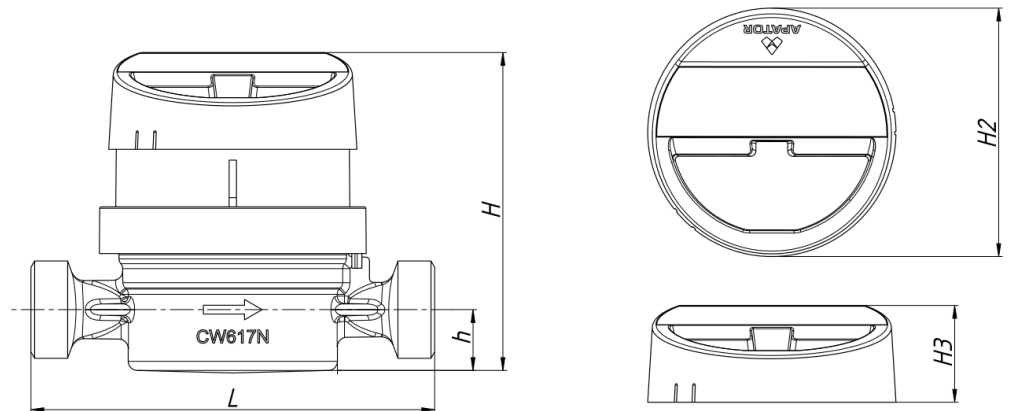

CONTACTS

APATOR METRA s.r.o.

Havlíčková 919/24

787 01 Šumperk

Czech Republic

Tel.: +420 583 718 261

E-mail: prodej@metra-su.cz

Web: www.metra-su.cz

Your distributor:

The manufacturer reserves the right to change design, technical specifications and accessories without prior notice.

K2024/04a