



EU-TYPE EXAMINATION CERTIFICATE

Number: TCM 311/19 - 5671

Addition 3

This addition replaces all previous versions of this certificate in full wording.

Page 1 from 11 pages

In accordance: with Directive 2014/32/EU of the European Parliament and of the Council on the harmonisation of the laws of the Member States relating to the making available on the market of measuring instruments (implemented in Czech Republic by Government Order No. 120/2016 Coll.).

Manufacturer: APATOR POWOGAZ S.A.
Jaryszki 1c
62-023 Žerniki
Poland

For: thermal energy meter - compact
type: Elf2

Accuracy class 2 or 3
mechanical environment class: M1
electromagnetic environment class: E1

Valid until: 7 November 2029

Document No: 0511-CS-A015-19

Description: Essential characteristics, approved conditions and special conditions, if any, are described in this certificate.

Date of issue: 29 April 2022

Certificate approved by:



RNDr. Pavel Klenovský

1 Measuring device description

Thermal energy meters, complete (compact) instruments type Elf2 are designed to measure a thermal energy which, in a heat exchange circuit, is given up by heat-conveying liquid in the sense of the Directive of the European Parliament and of the Council no. 2014/32/EU of measuring instruments, as amended.

Thermal energy meter Elf2 consists of an electronic calculator with a pair of Pt 500 sensors permanently integrated with a volume measuring flowmeter. The electronic system is located in a small tamper-proof enclosure which prevents access to electronic components and sensors after factory assembly. The base of the electronic system enclosure is connected to the flowmeter body with a band clip locked with a wire seal.

Flowmeter impeller features a disk made of an EM-immune metal. The impeller revolutions are measured by the electronic system with induction coils; only connecting the flowmeter to the electronic circuit makes the flow transducer complete; addition of the temperature sensor pair completes the compact flowmeter. The modern revolution detection method combines excellent metrological performance with resistance to strong magnetic fields. The flow transducer system resolution enables detection of as little as $\frac{1}{4}$ of rotor revolution; moreover, the implemented electronic calibration results in a very smooth error chart within the entire range of flow variations.

Temperature sensors are permanently soldered to the resolver PCB. Temperature is measured in 6-second intervals in the basic operating mode when flow is present and 2-second intervals during significant flow changes. If there is no flow present, the temperature is measured in 20-second intervals. The heat consumption is calculated and added to the total consumption register at an interval of at least 6 seconds only if volume gain occurs in the given period.

Electronic calculator consists of an electronic board with battery, and is equipped with LCD display and one button. Calculator is built in the plastic cover.

Sealing of all the meter, it is in part 4 of this Certificate.

The basic calculation formula for measured heat energy is given as:

$$Q = \int_{V_1}^{V_2} k (t_1 - t_2) dV$$

Q - quantity of heat energy

dV - volume of water (V1, V2)

k - temperature coefficient of water

t1 - supply water temperature

t2 - return water temperature

Thermal energy meters Elf2 can be equipped with distance reading interfaces. Next modules are to disposition:

M-Bus + 4 pulse inputs
M-Bus + 2 pulse inputs + 1 pulse output
RS 485 module (ModBus)
USB module
Wireless M-Bus module + 2 pulse inputs

Thermal energy meters Elf2 are manufactured according to the technical documentation of the company APATOR POWOGAZ S.A.,

- Declaration of manufacturer concerning development of meter SW by CRC-32 in accordance with actual WELMEC Guide 7.2 from 14.2.2020
- Technical specification (new issue) of compact heat meter Elf2 (for new version of SW, over 2.2), Nr. 2020.053.I.EN, October 2020.
- Letter of manufacturer DBR/22/2020 dated 28.10.2020 concerning battery protection by using of capacitor 2200 μ F (instead of 470 μ F) on PCB (reason: exchange of SW version on 3.0 and CRC16 on CRC32).
- Detail documentation, schemes and pictures of electronic as for the capacitor exchange, October 2020.

REMARK 1: HW and SW of the meter is prepared for measurements of thermal energy in cooling application, described in Statement of manufacturer over.

REMARK 2: Addition 2 concerns exchange of SW version on 3.0 and CRC16 on CRC32.

2 Basic technical data

2.1 Flow sensor

Factory marking:	JS90-0,6-T1	JS90-1-T1	JS90-1,5-T1	JS90-1,5-G1-T1	JS90-2,5-T1
Nominal diameter DN [mm]:	15	15	15	20	20
Lower limit of flowrate q_i [m ³ /h] - horizontal orientation H:	0.006	0.010	0.015	0.015	0.025
Lower limit of flowrate q_i [m ³ /h] - vertical orientation V:	0.012	0.020	0.030	0.030	0.050
Permanent flowrate q_p [m ³ /h]:	0.6	1.0	1.5	1.5	2.5
Upper limit of flowrate q_s [m ³ /h]:	1.2	2.0	3.0	3.0	5.0
Connection type: Screw thread	G $\frac{3}{4}$	G $\frac{3}{4}$	G $\frac{3}{4}$	G1	G1
Total length [mm]:	110	110	110	130	130
Orientation limitation:	Horizontal, H/ Vertical, V				
Accuracy class:	2 or 3				
Maximum admissible working pressure PS [bar]:	16				
Maximum pressure loss: [bar]	0.25 (ΔP_{25})				
Limits of temperature range ($\Theta_{min} \div \Theta_{max}$) [°C]:	0.1 \div 90				
Flow profile sensitivity (disturbance) classes:	U0, D0				
Liquid specification:	Water				
Direction of flow:	One direction, no backflow				

2.2 Calculator with temperature sensor pair

Limits of temperature range ($\Theta_{min} \div \Theta_{max}$) [°C]:	1 \div 105	
Limits of temperature difference [K]:	3 \div 104	
Limits in ambient temperature [°C]:	5 \div 55	
Type of temperature sensors:	Pt 500	
Place of the flow sensor installation:	Flow or return	
Supply:	Lithium battery 3.6 V; (2.6 or 5.2) Ah	
Protection class:	IP65	
Mechanical environments:	M1	
Electromagnetic environments:	E1	
Environmental class (EN 1434):	A (domestic use, indoor installations)	
Displayed units of energy:	GJ, kWh (Gcal, remark, this unit not subject of testing)	
Type of display:	LCD – 7 signs, height 7 mm	
Reading cycling	By button	
Output interface, auxiliary modules:	Described above - part 1	
Version of software, CRC	SW version:	CRC-32
	3.0	A78AA6A6
<p>SW version and CRC can be read on the LCD display. Next instructions must be follow:</p> <ol style="list-style-type: none"> 1. Press the push button for 5 seconds till the “- - - - 01” appears 2. Press the button shortly 3-times till the group “04” appears 3. Press the button for a long-time till the display test occurs 4. Press the button shortly 11-times till the version number is shown: “ur 3.0” 5. Press the button shortly once and the checksum is shown: “A78Acr” and “crcA6A6” (automatic on 2 rotating screens) 		

2.3 Temperature sensor pair

Type of temperature sensors:	Pt 500 / 2 wire
Limits of temperature range ($\Theta_{min} \div \Theta_{max}$) [°C]:	0 ÷ 105
Limits of temperature difference [K]:	3 ÷ 105
Mounted:	Direct
Length of pocket [mm]:	28 or 45
Length of cables [m]:	2
Specifications wires [mm ²], PU insulation:	2 × 0.25
Shield of cables:	No
Max. working pressure [MPa]:	1.6
Material of pocket:	Stainless steel, brass
Resistance of cables [Ω]:	0.30
Max. measurement current [mA]:	5
Minimal immersion depth [mm]:	26
Response time [s]:	≤ 3.2

2.4 Parameters and type of heat meters Elf2 interfaces

<i>M-BUS</i>	Unit	Value
Max voltage	V	42
Max interface current	mA	2
Max cable length	m	<1000
Transmission speed	Baud	300,600,1200, 2400,4800,9600

<i>IN</i> (potential free contact, active)	Unit	Value
Max voltage	V	6
Max current	mA	0,05
Isolation voltage	V	>500
Max cable length	m	10
Max input number	-	4 (2)
Impedance for potential free close input	k Ω	<10
Impedance for potential free open input	M Ω	>2

<i>OUT (opto-coupler)</i>	Unit	Value
Max voltage	V	24
Max current	mA	10
Isolation voltage	V	>500
Max cable length	m	10
Max frequency	Hz	1000

<i>RADIO</i>	Unit	Value
Frequency range	MHz	868,95
Neighboring channel interspace	kHz	±50
Frequency instability	kHz	<±2,5
Output power	mW	10
Sensitiveness	dBm	105
Power	Lithium battery	3 V, size ½AA
Antenna	Internal	¼ λ
Temperature range during exploitation	°C	5-55
Conformity	Wireless-Mbus	EN 13757-4
Type of received frames	Wireless-Mbus	T1

2.5 Interfaces of heat meters Elf2, details

Interface type:	M-BUS	IN	OUT
M-BUS + 4 pulse inputs	+	+	
M-BUS + 2 pulse inputs + pulse output	+	+	+
USB			+
RS485 ModBus			
Wireless M-Bus + 2 pulse inputs		+	

3 Test

Technical tests of the thermal energy meters Elf2 were performed in compliance with the International Recommendation OIML R 75 Edition 2006 (E) and with conformity to EN 1434-4:2016.

Results of shortened metrological tests are presented in Test Report Nr. 6015-PT-P0004-21 from 5.2.2021, issued by CMI.

Process of SW validation in accordance with WELMEC Guide 7.2:2018 is documented in TR Nr. 6011-PT-SW003-21, from 2.2.2021, issued by CMI

Statement of CMI, Testcom, October 2020, was taken in attention. Statement is aimed on small exchange of meter electronic in relation to EMC immunity.

3.1 The measuring device data

There are following data on the measurement device:

- The "CE" marking and supplementary metrology marking
- Number of EU-type examination certificate
- Manufacturer's mark or name and address
- Year of manufacture
- Measuring device type
- The serial number, pictures 2 on the other side of meter
- Unit of measurement: GJ, or kWh (Gcal), at least on LCD display
- Accuracy class 2 or 3
- Classification of mechanical, electrical and climatic environments (taken from table 2.2 above)
- The maximum admissible pressure PS (bar)
- Limits of temperature range
- Limits of temperature difference
- Place of the flow sensor installation (flow or return), available on label, resp. on display
- Direction of flow arrow on both sides of the meter body
- SW version 3.0, available on display, also in table 2.2
- CRC value A78AA6A6, available on display, also in table 2.2

Temperature sensors are marked by types, limits of temperature range and temperature difference. Installation of sensors (in flow or return pipe of the circuit) is identified by colors (red, blue).

4 Sealing, CRC marking, assembling

The connection of the electronic calculator with flow sensor body is protected by clamp on plastic ring with seal. Opening plastic cover of the calculator is protecting by sealed screw.

The enclosure base is fastened to the rest of the enclosure with four screws; the enclosure is sealed by applying a self-adhesive seal made of a special brittle sheet at the enclosure separation line, and on the fastening screw head opening. The electronic circuit features special pins for a jumper. The removal of the jumper disables access to calibration and configuration of metrological parameters of the heat meter. The part of the setup parameters which do not affect the measurement accuracy is adjustable by the user, i.e. the administrator or the technical service.

The location sealing and placement of serial number is described on pictures 1, 2 and 3.

Labels of the meter, pictures 4 and 5.

Display of meter with information about flow sensor installation, picture 6.

SW version and CRC, pictures 7, 8 and 9.

Mounting sealing, picture 10.

Assembling, picture 11.

Picture 1: Sealing of compact thermal energy meters type Elf2:

- not removable label protect the meters against opening and forbidden manipulation with HW and SW
- interface on back side of the meter is prepared for connection of selected communication modules, described in parts 1, 2.4 and 2.5.

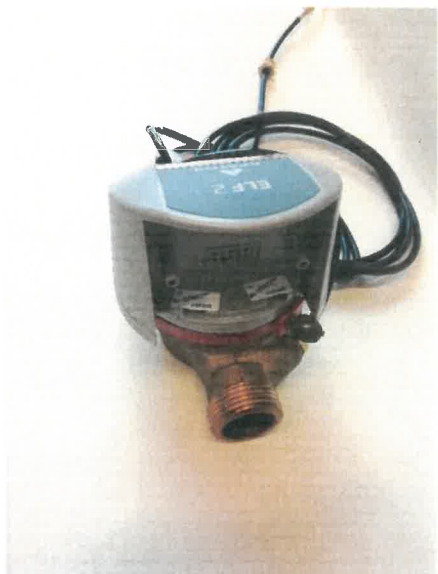

Picture 2: Sealing of compact thermal energy meters type Elf2, on side view, placement of serial number:



Picture 3: Sealing of compact thermal energy meters type Elf2 on plastic ring:



Picture 4: Front label of the meter:



Picture 5a: Side label of the meter with original address - with (f. inst. return) or without an information about installation of flow sensor:

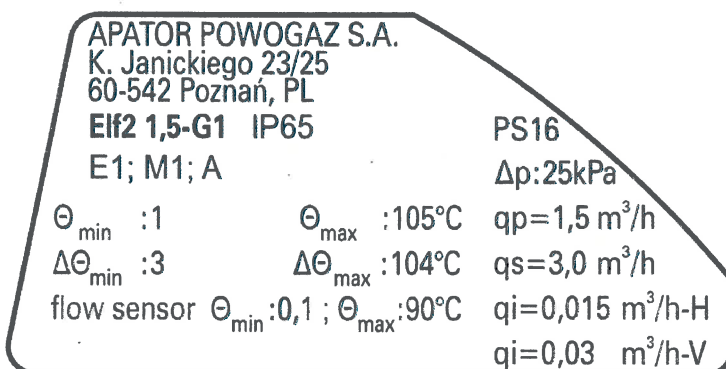
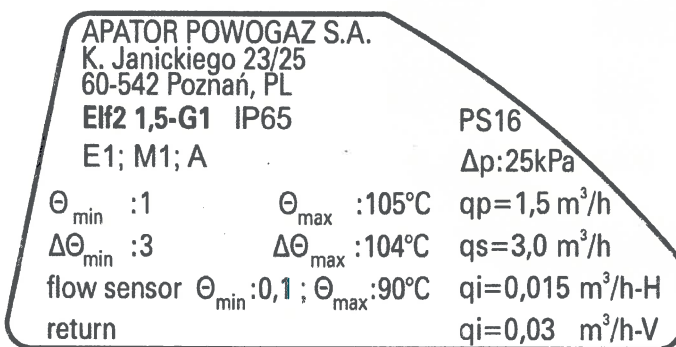

Picture 5b: Side label of the meter with new address - with (f. inst. return) or without an information about installation of flow sensor:

APATOR POWOGAZ S.A.
 Jaryszki 1c
 62-023 Żerniki, PL
Elf2 1,5-G1 IP65 PS16
 E1; M1; A Δp :25kPa
 Θ_{min} :1 Θ_{max} :105°C qp=1,5 m³/h
 $\Delta\Theta_{min}$:3 $\Delta\Theta_{max}$:104°C qs=3,0 m³/h
 flow sensor Θ_{min} :0,1 ; Θ_{max} :90°C qi=0,015 m³/h-H
 return qi=0,03 m³/h-V

APATOR POWOGAZ S.A.
 Jaryszki 1c
 62-023 Żerniki, PL
Elf2 1,5-G1 IP65 PS16
 E1; M1; A Δp :25kPa
 Θ_{min} :1 Θ_{max} :105°C qp=1,5 m³/h
 $\Delta\Theta_{min}$:3 $\Delta\Theta_{max}$:104°C qs=3,0 m³/h
 flow sensor Θ_{min} :0,1 ; Θ_{max} :90°C qi=0,015 m³/h-H
 supply qi=0,03 m³/h-V

APATOR POWOGAZ S.A.
 Jaryszki 1c
 62-023 Żerniki, PL
Elf2 1,5-G1 IP65 PS16
 E1; M1; A Δp :25kPa
 Θ_{min} :1 Θ_{max} :105°C qp=1,5 m³/h
 $\Delta\Theta_{min}$:3 $\Delta\Theta_{max}$:104°C qs=3,0 m³/h
 flow sensor Θ_{min} :0,1 ; Θ_{max} :90°C qi=0,015 m³/h-H
 qi=0,03 m³/h-V

Picture 6, Information about flow sensor installation, available on LCD display (here installed in return pipe – outlet)

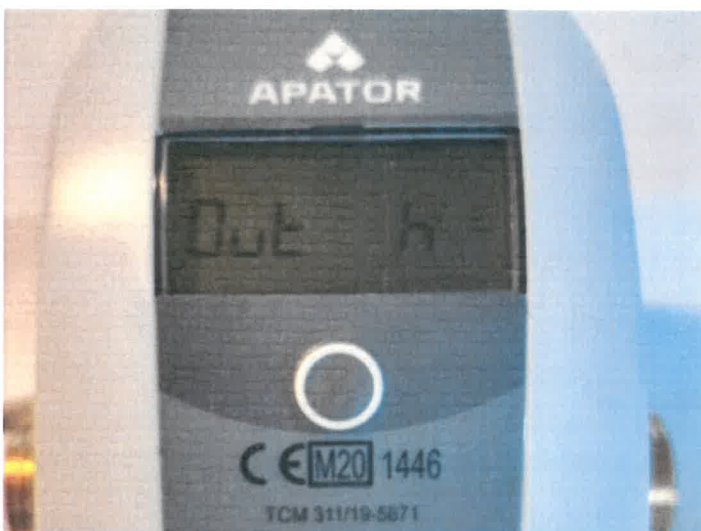

Picture 7, version of SW 3.0 on LCD display



Picture 8: 1st part CRC-32, A78A on LCD display

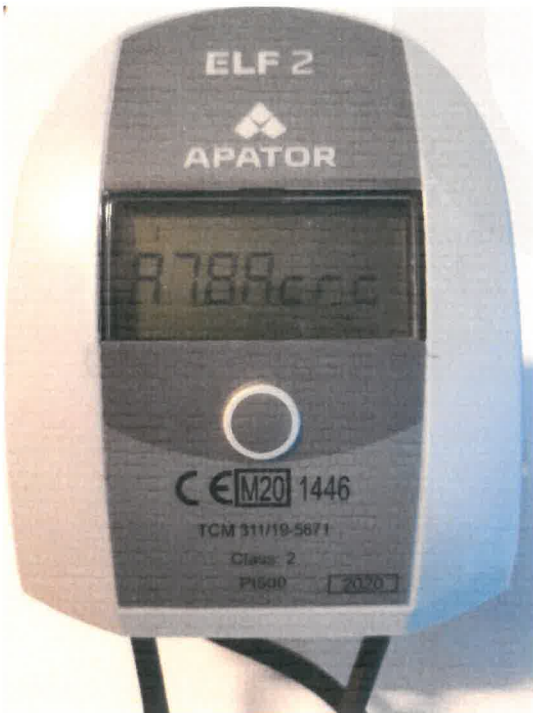

Picture 9: 2nd part CRC-32, A6A6 on LCD display

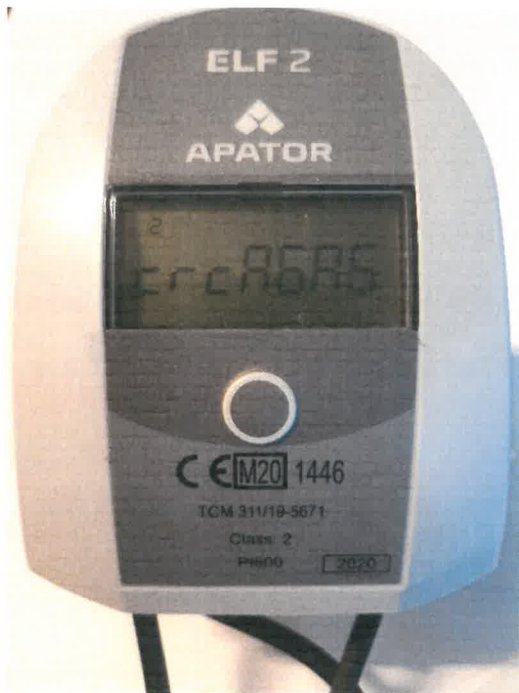

Picture 10: Mounting sealing of compact thermal energy meters type Elf2 after installing (recommendation of manufacturer):

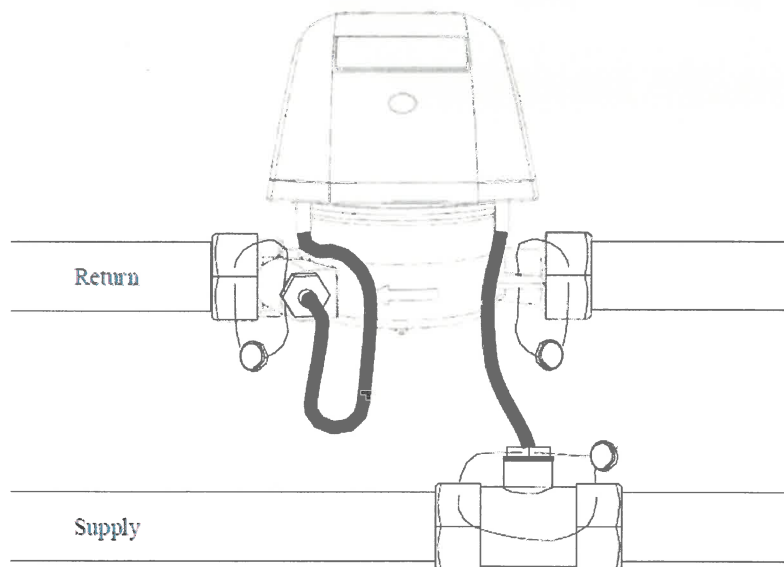

Picture 11: Assembling

