

THERMOSTAT TH 470.2

DESCRIPTION

Thermostat TH 470.2 for additional cooling is operated by changes of arching of bimetallic spherical cap (bimetallic membrane in following text). Arching of bimetallic membrane is changed by environment temperature and this change is transferred to thermostat switch mechanism.

Thermostat TH470.2 is made as one unit. Sensor and the electrical switch system are assembled, adjusted and enclosed in the thermostat body. Thermostat is installed into specified hole in the cooling system of engine. To install it, use thread M22x1.5 on the thermostat body and hexagon head OK 27. Thermostat is designed for single-wire circuit. Thermostat head with flat pins 6.3 is connected permanently with thermostat body. Connecting terminals are protected against electrochemical corrosion by cover filled with plastic lubricant. Thermostat is supplied with sealing ring diameter 22x27.



TECHNICAL DATA

Switch-on temperature	97°C + 2/3°C
Switch-off temperature	> 88°C
Rated contact load	12 V, 8 A DC
Connecting terminals	flat pins 6.3, ČSN EN 612 10
Weight	approx. 60 g
Lifetime	10 000 cycles

TECHNICAL DRAWINGS

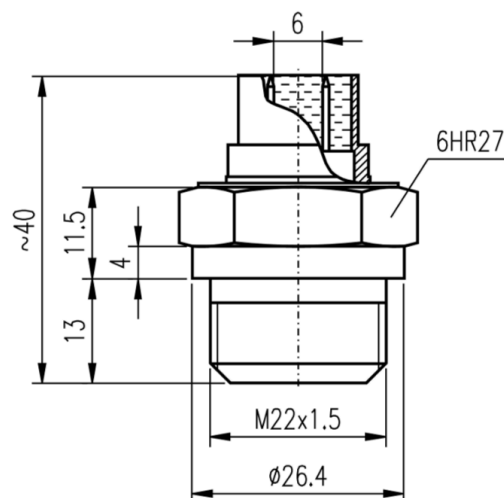

CONTACTS

APATOR METRA s.r.o.

Havlíčková 919/24

787 01 Šumperk

Czech Republic

Tel.: +420 583 718 261

E-mail: prodej@metra-su.cz

Web: www.metra-su.cz

Your distributor:

The manufacturer reserves the right to change design, technical specifications and accessories without prior notice.

K2024/03a