



Electronic radio module for water meter

E-RM 30

INSTALLATION AND SERVICE MANUAL

APATOR METRA s.r.o.

Havlíčková 919/24

787 01 Šumperk

tel.: +420 583 718

e-mail: prodej@metra-su.cz

<http://www.metra-su.cz>

Content

Introduction	3
1 Description	4
1.1 Type list	4
2 Construction and technical data	6
2.1 Technical data	6
2.1.1 Radio module E-RM 30 construction	8
3 Radio module's operation modes	9
3.1 Sleeping mode	9
3.2 Mode of automatic activation	9
3.3 Working mode	9
3.4 Error mode	9
4 Work with a radio module	10
4.1 Installation E-RM 30 to the water meter	10
4.2 Reading data, defining parameters and operating modes	10
4.3 Change of operation mode	10
4.3.1 Switch a radio module to the working mode	11
4.3.2 Switch a radio module to the mode of automatic activation	11
4.3.3 Switch a radio module to the sleeping mode	11
4.4 Electronic seal reactivation	12
5 Other information	13
5.1 Transporting	13
5.2 Storage	13
5.3 Application and disposal	13
5.4 Defects and their elimination	13
5.5 Warranty	13
6 Accompanying documentation	14
6.1 Ordering	14
6.2 Packing	14
7 Water meters	15
7.1 Choosing the right water meter size	15
7.2 Water meter JS	15
7.2.1 Single jet dry type water meter	15
7.2.2 Parameters	15
7.2.3 Structure	16
7.2.4 Testing at the receipt	16
7.2.5 Condition of correct installation of water meters	16

7.2.6	Filling with water and start – up of flow transducers	18
7.2.7	Water meter marking (example)	18
7.3	Water meter GSD8-RF	18

Introduction

Radio module E-RM 30 scans the data from specially designed water meter, processes them, save to the memory and transmits data via radio signal. Data sent by radio interface can be read without entering the flat and even entering the building. E-RM 30 together with electronic heat cost allocators E-ITN 30 protect your privacy and save your time due to remote data reading.

E-RM 30 rod antenna features a very good efficiency. Due to this high-quality signal it is possible to read data without entering the building eve in case of installation in the shaft of multiple storey building. Data reading can be made by billing company employee using mobile receiving unit. Data can be also read by central reading system CRS 40 permanently installed in the building if required. If radio heat cost allocators E-ITN 30 are also used, data are read simultaneously.

Every user can control current value on analogue dial of water meter. In contrast to the traditional water meter, radio module E-RM 30 distinguish the direction of water flow – it is thus possible to detect manipulation with water meter (its turning).

The radio module can be of course secured by conventional mechanical seal against its removal from water meter. The radio module is equipped with an electronic seal that allows you to identify unauthorized manipulation and record the exact date. Furthermore, some modules can detect attempts to manipulate the water meter by the use of an external magnetic field (e.g. the use of a strong magnet). Information about such manipulation is transmitted in radio signal.

Month consumptions for forward and back flow for past 12 months can be read from the radio module memory via infra-red interface.

1 Description

Radio module E-RM 30 is intended for record of data about consumed water – measured by mechanical water meter – and for remote reading of these data. Mechanical water meter is equipped with rotating circular disc with reflecting sector. Radio module permanently scan the surface of the disc – its speed and direction of rotation. Amount of consumed water is recorded and also direction of flow) forward flow or backflow).

Radio module E-RM does not dispose of display – is equipped with IR interface with bi-directional communication. Via this interface it is possible to set module parameters, switch between operational modes, get information about set parameters, module functions and measured values (e.g. chapter 4.2. Reading data, defining parameters and operating modes a 4.3. Change of operation mode).

Some models of the E-RM 30 (e.g. chapter 1.1. Type list) are able to detect attempts to manipulate the water meter by using an external magnetic field (for example by using a magnet). The actual transfer of data between the water meter and the radio module is based on an optical principle (just like the radio module itself) and is therefore not affected by a magnetic field.

The radio module is equipped with electronic seals (and also the option to use mechanical seals) in order to safeguard the module from tampering. If there is an unauthorised removal of the module from the meter, the device records and stores the date of the offence and transmits this information by radio signal. The unit remains in operating mode and after re-activation and re-setting it continues to measure the flow in the water meter.

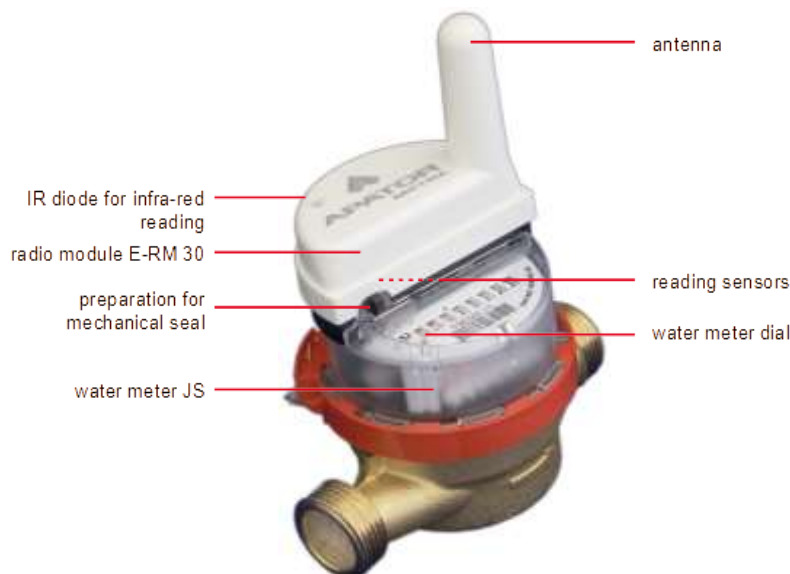

Picture 1: radio module E-RM 30 with water meter JS

1.1 Type list

Type	Water meter	Antenna	Billing period	Est. battery lifetime (year)	Magnetic field detection
E-RM 30.301	JS	Standard	Year	10+1 (reserve)	Yes
E-RM 30.302			Month		

Warnings!

E-RM 30 radio modules designed for one type of water meter cannot be used for another type. The manufacturer is not responsible for measurement errors caused by mounting on another type of water meter.

2 Construction and technical data

2.1 Technical data

Environment temperature	5 to 50 °C
Billing period	e.g. chapter 2.1. Chyba! Nenalezen zdroj odkazů.
Calendar functions	month consumption, 12 months history (standard flow and backflow)
Data reading	radio and infra-red interface
Protection against cheating	backflow detection for example, reversal of the meter electronic seal – records the data of any manipulation or removal of device magnetic pole detection (> 3 mT) – only E-RM 30.3** an option to mechanically lock the radio module to the water meter
Backup data	daily backup of measured values including real time
Function control	automatic
Dimensions	70 x 44 x 71 mm
Power supply	lithium battery 3 V
Calculat. battery lifetime	e.g. chapter 2.1. Chyba! Nenalezen zdroj odkazů.
Material	polycarbonate
IP code	IP64
Class of climate and mechanical environment	B
Class of electromagnetic environment	E1
Working frequency	868 MHz
Transmitting wattage	< 5 mW
Class of operating cycle	1 (percent of operating cycle <0,1 %)
Length of transmission	< 8 ms
Transmission frequency	E-RM 30.**1 (year billing period) 60-66 seconds first month after beginning of billing period 240-246 seconds rest of the year E-RM 30.**2 (month billing period) 60-66 seconds first 3 days after beginning of billing period 240-246 seconds rest of the year

Transmission	<p>up to 500 m (with standard antenna, reading carried out by antenna ZZ P- 868)</p> <p><i>Rem.: all metal parts of construction (switch rooms, armouring, lifts, etc.) can negatively affect the range of radio signal.</i></p>
Data coding	yes
Data available via infra-red interface (for exact data structure see manual for decoding software)	<p>E-RM 30.***</p> <p>serial number</p> <p>consumption in actual billing period, standard flow</p> <p>consumption in actual billing period, back flow</p> <p>consumption in past billing period, standard flow</p> <p>consumption in past billing period, back flow</p> <p>reading date (day, month, year)</p> <p>date of billing period beginning</p> <p>electronic seal status</p> <p>magnetic field detector status (ERM 30.3** only)</p>
Data available via infra-red interface (for exact data structure see manual for decoding software)	<p>E-RM 30.**1</p> <p>serial number</p> <p>date of billing period beginning</p> <p>month consumptions, standard flow (12 months history)</p> <p>month consumptions, backflow (12 months history)</p> <p>reading date</p> <p>consumption in actual billing period, standard flow</p> <p>consumption in actual billing period, back flow</p> <p>consumption in past billing period, standard flow</p> <p>consumption in past billing period, back flow</p> <p>consumption in billing period before last, standard flow</p> <p>consumption in billing period before last, back flow</p> <p>date of electronic seal activation</p> <p>date of electronic seal breakage</p> <p>operation mode of radio module</p> <p>date of magnetic field disruption (only E-RM 30.3**)</p> <p>E-RM 30.**2</p> <p>serial number</p> <p>date of billing period beginning</p> <p>month consumptions, standard flow (12 months history)</p> <p>month consumptions, backflow (12 months history)</p>

	reading date consumption in actual billing period, standard flow consumption in actual billing period, back flow electronic seal activation date date of electronic seal breakage operation mode of radio module date of magnetic field disruption (only E-RM 30.3**)
--	---

2.1.1 Radio module E-RM 30 construction

The E-RM 30 unit consists of a top part with an aperture for infrared communication and a bottom part for detecting the water meter. Both parts provide a protective covering for the printed circuit boards, electronic components, antenna and battery. The device is equipped with a 16-bit micro processor with low power consumption and a radio transmission module, powered by lithium batteries. The bottom part is attached to the top part by 3 self tapping screws and protected against water ingress by a seal.

3 Radio module's operation modes

Radio module E-RM 30 can be in four operation modes:

- Sleeping mode
- Automatic activation mode
- Working mode
- Error mode

Description, how to change an operation mode find in chapter 4.3 Change of operation mode.

3.1 Sleeping mode

Sleeping mode is suitable for prolonged storage prior to radio module use. In this mode device does not scan position of water meter disc (does not measure amount of consumed water) and does not transmit measured data. Radio module only actualizes real time. Electronic seal is not activated and consumption of electric power is minimized. The storage period should not exceed one year.

After installation and sealing the radio module is necessary to do an activation – description e.g. chapter 4.3.1. Switch a radio module to the working mode.

Warning!

Without an activation, radio module E-RM 30 is not reading and sending any data.

3.2 Mode of automatic activation

Mode of automatic activation makes installation of water meter with radio module easier. Installation consists only from putting module on water meter and installation of mechanical seal.

In mode of automatic activation, module regularly tests disc presence. If the presence is detected, measuring of water consumption is switched on. After 5 liters flows trough, radio module is switched to working mode and electronic seal is activated. Date of electronic seal activation is saved to radio module memory.

We recommend to do an activation by 5 liters flow immediately after the installation. Otherwise radio module E-RM 30 is not sending any data and it is not possible to check radio modules availability and functionality with radio reading unit.

It is also possible to do an activation by chapter 4.3.1. Switch a radio module to the working mode.

3.3 Working mode

Radio module in working mode measures consumption of water, transmits the data in regular intervals, actualizes real time and tests state of electronic seal.

3.4 Error mode

Radio module is switched to error mode when date of billing period beginning is wrong, RAM memory content is invalid or error occurs when saving data to flash memory. Module does not scan disc position (does not measure water consumption), does not transmit measured data, does not test state of electronic seal. It only actualizes real time.

4 Work with a radio module

4.1 Installation E-RM 30 to the water meter

1. Check the condition of the intended water meter and its housing. If there is any damage or contamination, clean or replace the meter.
2. Remove the cardboard plugs which are used to protect the E-RM 30 radio module's sensors during transport. Retain the plugs for covering the sensors during any mode changes (4.3 Change of operation mode).
3. Attach the radio module to the water meter using the snap-on lock and then seal it. It is recommended that plastic or adhesive paper seals are used.
4. Activate the radio module depending on the required operating mode

4.2 Reading data, defining parameters and operating modes

Given that the radio module RM E-30 is not equipped with a display, it is possible to obtain basic information about the active mode, the start date of the billing period, and electronic seals using infrared reading unit IRU 10.00.

The IRU 10.00 displays information related to the last unit it has read. It is therefore necessary to carry out a data reading from the radio module so that you can view the parameters and operating mode. During the reading it is necessary to put on the viewing screen so as to avoid interference from ambient light sources. The front of the meter reading head should be in contact with the plastic cover of the infrared reading diodes inside the unit (e.g. Picture 2: Data reading from E-RM 30 with IRU 10.00).

For more information about reading data, display parameters and operating mode, refer to the Installation and service manual for the IRU 10.00.

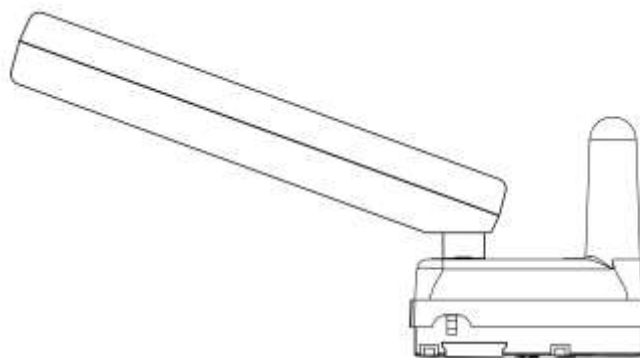

Picture 2: Data reading from E-RM 30 with IRU 10.00

4.3 Change of operation mode

Using the infrared reading unit, the IRU 10.00, it is possible to change the operating modes of the E-RM30. In individual operating modes it is only possible to make certain changes (see table below). It is therefore advisable to first check the current operating mode of the radio module (e.g. chapter 4.2. Reading data, defining parameters and operating modes) and then change the mode.

Actual operation mode	Modes to which the module can be switched
Sleeping mode	Mode of automatic activation Working mode
Mode of automatic activation	Sleeping mode Working mode
Working mode	Sleeping mode
Error mode	-

Warning!

If changing the operating mode requires removal of the radio module from the water meter (or changing the water meter), the light sensors in the unit should not be exposed to unnecessary light. It is therefore advisable to cover the sensors with the sensor plugs supplied for transport

4.3.1 Switch a radio module to the working mode

Switching the radio module into working mode is possible from sleep mode and mode of automatic activation. The radio module must be mounted to a water meter due to the detection of reflective targets. The E-RM 30 should also be assured against the movement of mechanical seals.

1. On the meter reading unit, when spare capacity is displayed (for example, 494) switch to the submenu by pressing and holding the button until --A-- is displayed.
2. On the meter reading unit, in the submenu, select "Pro" and hold down the button until -A- is displayed.
3. Readiness of the IRU10.00 is indicated by -PrE-. Place the readout head onto the infrared viewing port of the E-RM 30 and press the button briefly. Ongoing communication is indicated by IP on the viewing screen.
4. A successful mode change is indicated by a single beep and the display showing o. Pro .
5. An unsuccessful mode change is indicated by four beeps and the display showing E. Pro.

For more information, refer to the Installation and service manual for the IRU 10.00.

4.3.2 Switch a radio module to the mode of automatic activation

Switching the radio module to mode of automatic activation is only possible from sleeping mode. The radio module must not be attached to a water meter and the optical sensors should be covered (see above).

Warning!

When the radio module is changed from sleeping mode to mode of automatic activation whilst attached to a water meter, do not let it run dry after activation by a 5 litre through-flow. In that case, remove the unit from the water meter, re-attach it to the water meter and reactivate with a 5 litre through-flow.

1. On the meter reading unit, when spare capacity is displayed (for example, 494) switch to the submenu by pressing and holding the button until --A-- is displayed.
2. On the meter reading unit, in the submenu, select "rAA" and hold down the button until -A- is displayed. --A--.
3. Readiness of the IRU10.00 is indicated by -PrE-. Place the readout head onto the infrared viewing port of the E-RM 30 and press the button briefly. Ongoing communication is indicated by IP on the viewing screen.
4. A successful mode change is indicated by a single beep and the display showing o. rAA.
5. An unsuccessful mode change is indicated by four beeps and the display showing E. rAA.

For more information, refer to Installation and service manual for IRU 10.00

4.3.3 Switch a radio module to the sleeping mode

Switching the radio module into sleeping mode is possible from operating mode and mode of automatic activation. The radio module must not be attached to a water meter and the optical sensors should be covered (see above). In the vent of a change from operating mode, there will also be a reach of the electronic seal.

1. On the meter reading unit, when spare capacity is displayed (for example, 494) switch to the submenu by pressing and holding the button until --A-- is displayed.

2. On the meter reading unit, in the submenu, select "uPr" and hold down the button until --A-- is displayed. --A--.
3. Readiness of the IRU10.00 is indicated by -PrE-. Place the readout head onto the infrared viewing port of the E-RM 30 and press the button briefly. Ongoing communication is indicated by IP on the viewing screen.
4. A successful mode change is indicated by a single beep and the display showing o. uPr.
5. An unsuccessful mode change is indicated by four beeps and the display showing E. uPr.

For more information, refer to the Installation and service manual for the IRU 10.00.

4.4 Electronic seal reactivation

Reactivation of electronic seal is possible to do by following steps:

1. Remote radio module (if is still installed on water meter). Radio module is now in working mode and has broken electronic seal.
2. Cover optical sensors with black cover used during module transportation.
3. Switch a radio module to the sleeping mode with an infra-red reading unit IRU 10.00 e.g. chapter 4.3.3. Switch a radio module to the sleeping mode.
4. Activate a radio module in one of two following steps. During an installation, electronic seal will be reactivated.
 - Switch a radio module to the mode of automatic activation with an infra-red reading unit IRU 10.00 (chapter 4.3.2. Switch a radio module to the mode of automatic activation), install the radio module to the water meter, seal it and activate it by 5 liters flow.
 - Install the radio module to the water meter, seal it and switch a radio module to the working mode with infra-red reading unit IRU 10.00 (chapter 4.3.1. Switch a radio module to the working mode).
5. Radio module is now in a working mode and electronic seal is activated and unbroken.

5 Other information

5.1 Transporting

E-RM 30 radio modules can be transported under following conditions:

- Devices can be transported by all usual covered means of transport
- Devices must be in original package
- Originally packed devices must be stored and secured to avoid mechanical damages during transportation
- **Devices can't be transported together with aggressive substances**
- Temperature during transportation from 0 °C to + 55 °C
- Relative humidity from 45 % to 75 %

5.2 Storage

Radio module E-RM 30 is electrical device and can be stored under these conditions:

- Devices must be originally packed by manufacturer
- Storage temperature from + 10 °C to + 30 °C
- Relative humidity from 45 % to 75 %
- Devices must be stored in clean covered areas without aggressive substances and stored properly to avoid mechanical damage

5.3 Application and disposal



"This device is subject to a waste management in accordance with local legislation."

5.4 Defects and their elimination

Any E-RM 30 defect should be repaired by manufacturer only.

5.5 Warranty

If device is installed and handled according to manufacturer instructions mentioned in installation and service manual, manufacturer provide warranty under the valid legislation unless agreed differently.

The warranty is void if device was used contrary to installation and service manual or damaged:

- During transport or storage by customer or reseller
- When mounted or dismantled to the customer device
- Because of improper handling or installation into other device than agreed in manual
- If the product was exposed to different environment agreed in manual
- If mechanically or in other way damaged by user

6 Accompanying documentation

6.1 Ordering

Order must include Setting protocol that is available on web side for business partners. In every order following items must be specified:

- Quantity
- Type
- Attach Setting protocol
- Spare parts (extra pcs)
- Delivery date
- Method of transport

Order example: 100 pcs E-RM 30, required delivery 28.3. 2024, EXW + filled Setting protocol

6.2 Packing

Packing sheet is included in every box (e.g. Picture 3: Packing sheet) with mark of producer, device type, number of items and their serial numbers, packing date and the name of operative who checked and packed the products

		BALÍČÍ LIST	
		Výrobní zakázka:	
Výrobek: Elektronický rádiový modul E-RM 30			
Výrobní číslo			
Měsíc / rok výroby	Počáteční výrobní číslo	Konečné výrobní číslo	
Obsah balení			
Díl	Počet ks		
Rádiový modul E-RM 30			
Vodotěsník			
Balení:			
Datum balení:		Podpis:	
Kontrolóv:			
Datum kontroly:		Podpis:	

V případě nedostatku (přebytku) materiálu, uveďte prosím při reklamaci jméno pracovníka balení.

2011/026

APATOR METRA s.r.o., Havlíčkova 618/24, 170 04 Bumpín, IČ 258200152, ZSŘEKOVÝ ZSC CZ00004175
 Zlatá ul. Dobruška výhled, Rokytný stouk v Čechách, 460 01, rožňa 40113
 tel: +420 562 718 111, fax: +420 562 718 115, e-mail: prodej@metra.cz, www: http://www.metra.cz.cz

Picture 3: Packing sheet

7 Water meters

7.1 Choosing the right water meter size

The main criteria for choosing the right water meter size (nominal diameter) should always be the water meter working conditions that is the average and maximum value of a passing water working flow.

When a water meter is too large, it does not increase the investment cost, but also has lower accuracy in case of small water flow. A too small water meter can cause its overload and simultaneously quicken the wear of its active parts.

It is recommended to choose the size of the water meter so that the size of the largest expected jet flow in the system between 0.45 and 0.6 of the water meter constant jet flow Q_3 .

7.2 Water meter JS

7.2.1 Single jet dry type water meter

Single jet dry type water meter consists of two basic units: measurement unit and counting mechanism. The main elements of the measurement unit are: a body with a sieve places in an inlet channel, a vane, a sealing plate. Main components of a counting mechanism are: a gear set, a roll set and a counter cover. The mechanism is attached to the unit by means of fastening ring and after legalisation, sealed with lead.

Single jet water meter vane is propelled by a jet of water which pushes its blades along the vane perimeter and it is the only movable element submerged in water. Rotor rotation is conveyed by a magnetic head clutch, through the sealing plate. Dry counter, sealed air-tight in separate module, sums the flow of measured water and displays the result in digital, easy to read manner. Counter is fitted with a motion detector which makes it possible to automate regulation and legalisation.

The regulating device is protected from tampering by a lead seal. Thanks to a special design of rotor bearings and the choice of corrosion and abrasion resistant materials, the water meter is characterised by high durability.

7.2.2 Parameters

Type	cold water warm water	JS-1,6 JS90-1,6	JS-2,5 JS90-2,5	JS-2,5-G1 JS90-2,5-G1	JS-4 JS90-4
Nominal diameter	[mm]	15		20	
Permanent flow rate Q_3	[m ³ /h]	1,6	2,5		4
Overload flow rate Q_4	[m ³ /h]	2	3,125		5
Minimum flow rate Q_1 (horizontal / vertical installation)	[dm ³ /h]	16 / 32 20 / 40	25 / 50 31,25 / 62,5		40 / 80 50 / 100
Transition flow rate Q_2 (horizontal / vertical installation)	[dm ³ /h]	25,6 / 51,2 32 / 64	40 / 80 50 / 100		64 / 128 80 / 160
Maximum permissible error (Q_2 to Q_4)		±2 % ±3 %			
Measuring range R (Q_3 / Q_1) (horizontal / vertical installation)		100 / 50 80 / 40			
Max. working temperature	[°C]	30 90			
Max. working pressure		1,6 MPa (16 bar)			
Length	[mm]	110		130	
Conformity		MID, EN 14154, OIML R49			

7.2.3 Structure



Picture 4: Water meter structure

7.2.4 Testing at the receipt

The water meter supplied should be checked for possible external damage which occurred during transport, especially the body and threaded connectors and the counter cover. Also, check the condition of lead seals, date of verification and labelling of a water meter.

The following markings are located on the plaque or a body of water meter:

- Name and marking of a manufacturer
- Mark of test type according to MID
- Manufacturer's mark type
- Water meter number
- Metrologic marking consists of an upper case M and two last digits of the water meter year of production
- Notified person number
- Flow direction, as an arrow
- V or H marking for vertical or horizontal pipes (or both)
- Jet flow value Q_3
- Q_1 and Q_3 ratio
- Marking of measurement unit in m^3 (on the counter dial)
- Value of the maximum pressure loss ΔP
- Value of upper pressure limit: PN16

7.2.5 Condition of correct installation of water meters

1. Place of installation for water meters should be easily accessible for installation, operation, reading indications, protected from negative atmospheric conditions and protected from influence of electrical and gas installations. In case there is no such place, the water meter may be installed in the water meter well and additionally the water meter and its equipment should be installed far enough from the well bottom.

2. In the location of installation, the water meter can't be at risk of being hit or be subjected to vibrations caused by other devices in the vicinity or subjected to high ambient air temperature, contamination, flooding and corrosive action of the surroundings. Temperature in the installation location should not be lower than 4 °C. The water meter should be protected from influence of such hydraulic phenomena such as cavitation or hydrodynamic water hammering.
3. Before and after the water meter provide the valves in order to cut off the water supply if there is need for de-installation or repair. Use valves which can entirely reveal the cross – section of a water pipe.
4. In case of expected water contamination during time of operation, install a filter or a setting tank between a valve and a straight pipe section and before the water meter.
5. For an installation of a water meter which does not cause strain in the body it is recommended to use compensative connectors installed at the output.
6. The pipe in the installation location should be shaped so that there is no possibility for an air pocket to be created in the water meter. Water meter has to be entirely filled with water, so the water pipe after the water meter cannot decline. (Picture 5: Water meter installation).

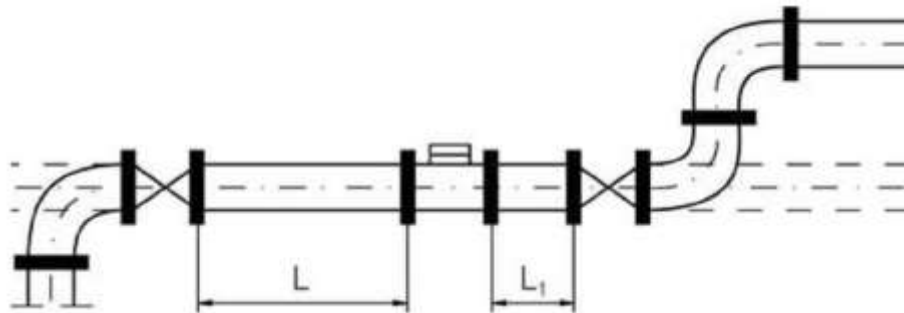

Picture 5: Water meter installation

7. Water meter should not be under risk of excessive strain caused by pipelines and equipment. If necessary, install it on a pedestal or in a grip. What is more, the pipes connecting on the inlet and outlet side should be adequately fastened, so that no part of the system is dislocated by the water when the water meter is de-installed or disconnected from one side.
8. During installing a meter in the water network, observe the correct water meter orientation according to the design: for horizontal, vertical and diagonal operation. (Picture 6: Sample permitted installation positions).

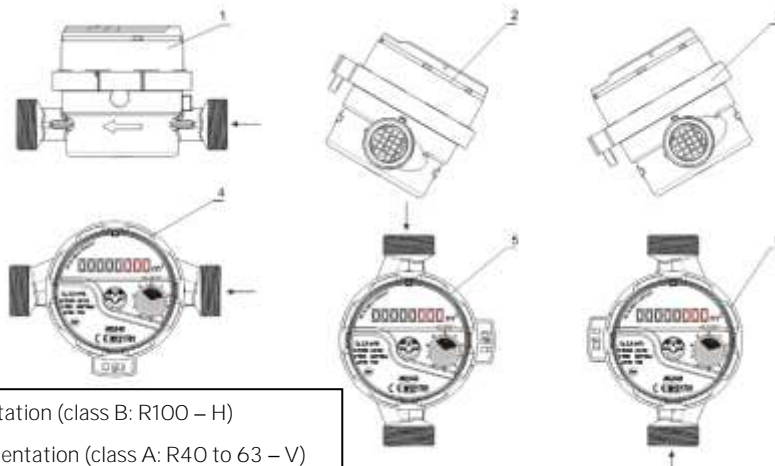

- | |
|---|
| 1 Horizontal orientation (class B: R100 – H) |
| 2, 3 – Diagonal orientation (class A: R40 to 63 – V) |
| 4, 5, 6 – Vertical orientation (class A: R40 to 63 – V) |

Picture 6: Sample permitted installation positions

9. When using typical connectors, using other straight sections before (U0) and after (D0) the device is not required.

However, in case of installing devices after a double elbow. Non – return valve or a pupm, provide a straight pipe section $L=5 \times \text{DN}$ (device nominal diameter) before the device (U5) and after the device $L1=3 \times \text{DN}$ (D3) (Illustration 5: Water meter installation).

10. The pipe sections before and after the water meter should be coaxial. Gaskets should be placed concentrically in relation to the pipe.
11. Water flow through the water meter should correspond to the direction of arrows placed on both sides of the body.

Warning!

When the water meter is connected, performing welding works is not allowed, as it will cause damage to it.

7.2.6 Filling with water and start – up of flow transducers

1. Before installing the water meter, the pipeline should be flushed in order to remove contamination and the filter (if it is used) should be cleaned. During flushing, use a spigot to replace the water meter.
2. Before installation, check the operation of a water meter by starting a rotating motion of a rotor while observing the rotation or the rotation of the counter indicators. Check the lead seal condition.
3. Before installing the water meter water should be supplied freely to the pipeline with the vents open so that the air that leaves the system does not cause excessive water meter rotations, which causes the device damage.
4. During operation, the valves before and after the water meter should be entirely open.
5. After performing all the actions related to the start-up, check the water meter operation by observing the increase of the counter indication.
6. During operation, check whether the actual operating conditions correspond to the water meter intended use, in particular in terms of permitted pressure, temperature and flow.

7.2.7 Water meter marking (example)

The first two letters indicate the type of water meter, followed by a number indicating the temperature class. The continuous flow rate is separated by a dash followed by the designation of the non-standard connection thread.

Example of serial number: JS 90 – 2.5 – G1

7.3 Water meter GSD8-RF

Nominal flow Q_n	1,5 m ³ /h
Maximal flow Q_{max}	3 m ³ /h
Max. working pressure	16 bar
Class of accuracy	B – horizontal installing A – vertical installing
Max. working temperature	30 °C – water meter for cold water 90 °C – water meter for warm water

E-RM 30

Návod k instalaci, servisu a obsluze



M2024/03

Dimension	110 x 70 x 74
Weight	0,5 kg