

TH 160



Description

Thermostat consists of a stem (temperature sensor) and a switch head. Changes of sensor dilatation are transferred via lever to a switch. Thermostats are made either in disconnecting design (2 terminals) or in switching design (3 terminals). Screw terminal allow to connect wires with diameter up to 4 mm. Protective cable must be connected to protective terminal. The standard thermostat is equipped with terminal cover to prevent accidental contact. Requirement for thermostat without this cover must be indicated in order. Avoid impacts on stem and head as well as stem deformations during installation. Thermostat well can be ordered as accessory.

Temperature setting

1. Regulation knob - thermostats TH 160, TH 160.1, TH 160.2, TH 163, TH 164, TH 166, TH 167 and TH 169. Temperature can be changed in control range by user.
2. In manufacturer according specification in order. Set temperature can not be changed by user (TH 162 and TH 165).

Technické údaje

Setting accuracy	± 10 % from the highest rated switching temperature
Stem diameter	8 mm
Max. temperature of the switch head	120 °C
Weight	approx. 0,25 to 0,35 kg
Protection	IP 00
Lifetime	10 000 cycles

Type	Control range [°C]	Switching difference [K]	Stem length L ₁ ±3 [mm]	Thermostat length	Rated voltage, rated current	Number of termi-
TH 160	20-80	2÷8	315	388	250 V, 15 A AC	2
TH 160.1	20-75	2÷8	315	388	250 V, 15 A AC	2
TH 160.2	20-80	2÷8	315	388	250 V, 15 A AC	3
TH 162	20-160	1÷16	100	164	250 V, 15 A AC	3
TH 163	50-90	6÷16	100	173	250 V, 15 A AC	3
TH 164	30-160	2÷10	160	233	250 V, 15 A AC	3
TH 165	20-200	1÷10	160	224	250 V, 15 A AC	3
TH 166	100-200	1÷10	200	273	250 V, 15 A AC	3
TH 167	20-100	1÷10	250	323	250 V, 15 A AC	3
TH 167.1	-10-50	1÷10	250	323	250 V, 15 A AC	3
TH 169	60-120	2÷8	315	388	250 V, 15 A AC	2

Technical drawings

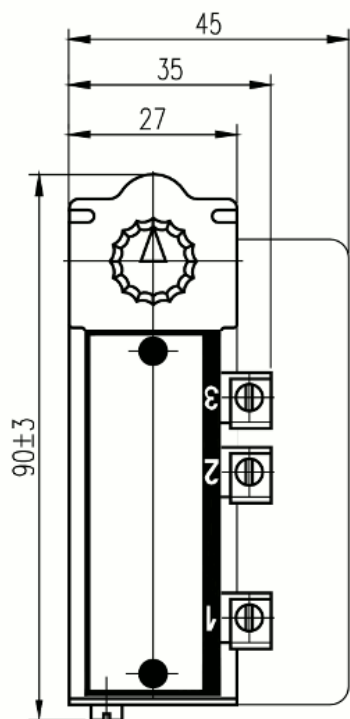
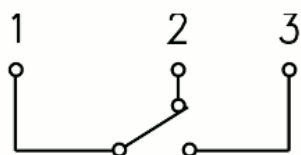
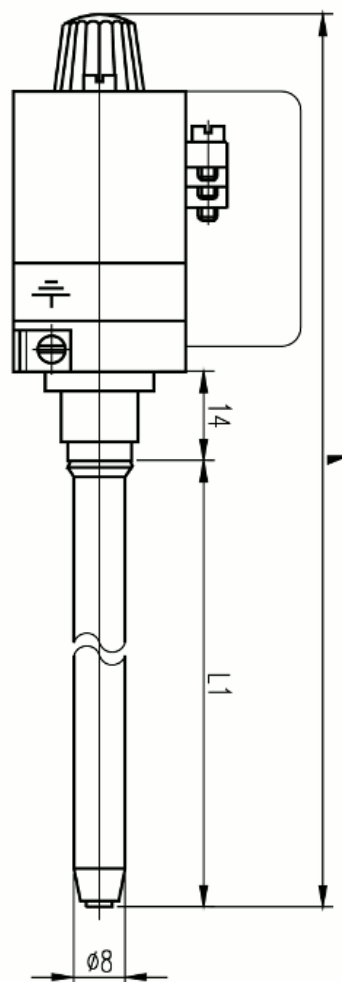
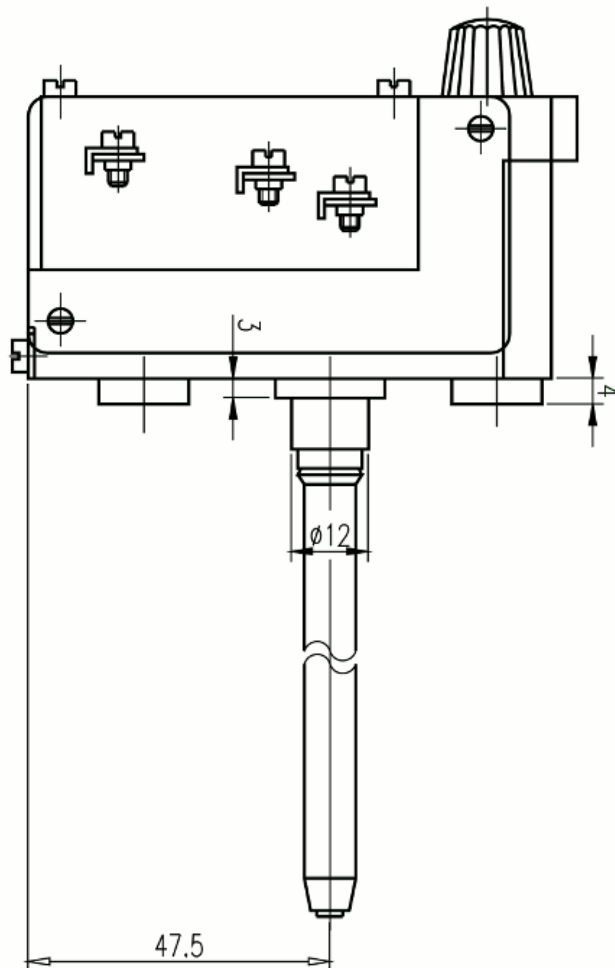

Contacts

APATOR METRA s. r. o.

Havlíčková 919/24
787 01 Šumperk
Czech Republic

Tel.: +420 583 718 261
Fax.: +420 583 718 150
E-mail: prodej@metra-su.cz
WWW: www.metra-su.cz

Your distributor:

The manufacturer reserves the right to change design, technical specifications and accessories without prior notice.