

THERMOSTATS TH 220, TH 221

DESCRIPTION

Thermostat consists of a stem and switch head. Temperature-sensitive element is formed by brass tube of the stem. Temperature-depending dilatation of the tube is transferred by invar rod to switch mechanism. The switch mechanism is snap-action single-pole switch. Switch mechanism is closed in thermostat head. Temperature scale is marked directly on the regulation knob. The thermostat can be mounted with screws using two holes at its base plate. Avoid mechanical stress of stem during installation. When used in vibrating equipment, attach the free end of the stem (but do not restrict the dilatation) and fix the set temperature by tightening of the locking screw. Contacts are bridged by capacitors for switching of the DC current.



ADVANTAGES

- High sensitivity
- Resistant to dust and humid environment

TECHNICAL DATA

Control range	-20°C to +60°C
Switching difference	1-3K
Setting accuracy	± 5% from the highest rated switching temperature
Rated voltage, rated current	60V, 1A DC; 120V, 0,5A DC (TH 220) 250V, 15A AC (TH 221)
Stem length	560 mm
Weight	approx. 0,8 kg
Protection	IP 44
Resistace to external influences	Head resistant to influences of class AB7, AE3, AM1, AN1, BE1
Max. Temperature of the switch head	120°C
Max. Temperature of the stem	140°C
Lifetime	10 000 cycles

TECHNICAL DRAWINGS

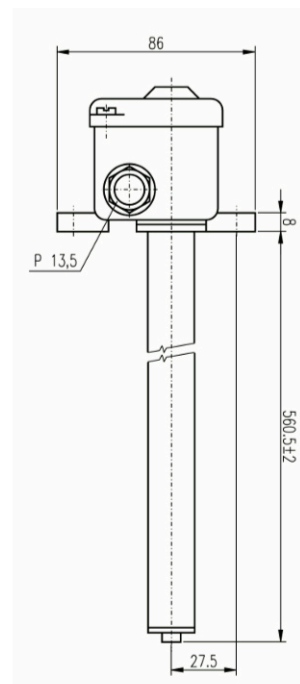
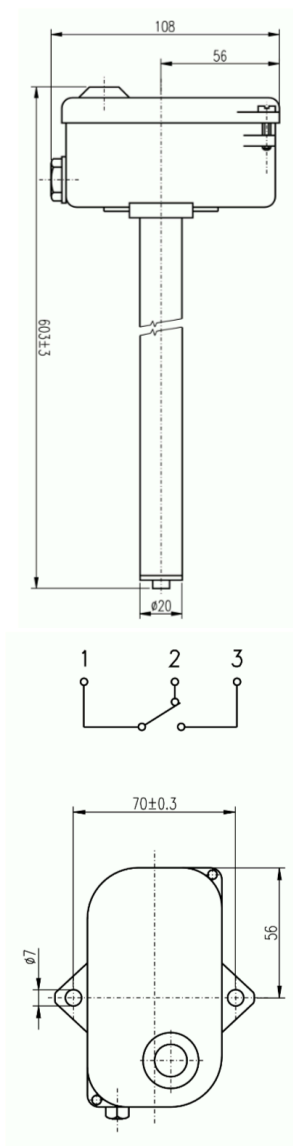

CONTACTS

APATOR METRA s.r.o.

Havlíčková 919/24
787 01 Šumperk
Czech Republic

Tel.: +420 583 718 261
E-mail: prodej@metra-su.cz
Web: www.metra-su.cz

Your distributor:

The manufacturer reserves the right to change design, technical specifications and accessories without prior notice.

K2024/03a